

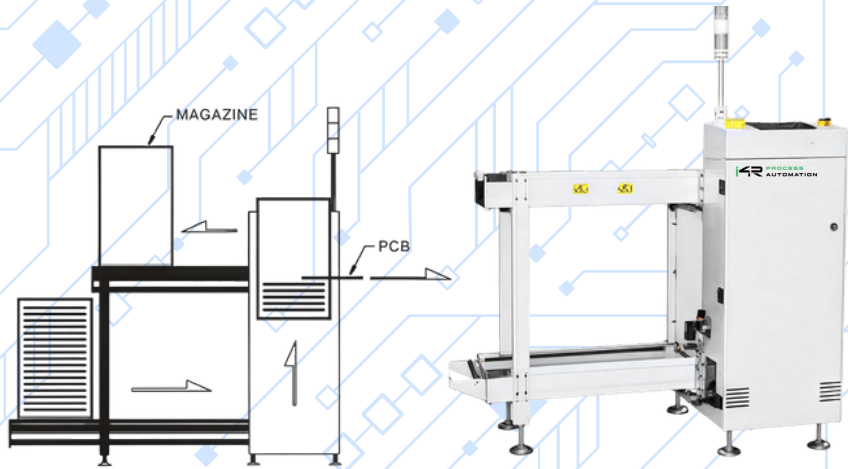

PCB HANDLING



www.solucinde.com



Magazine Loader

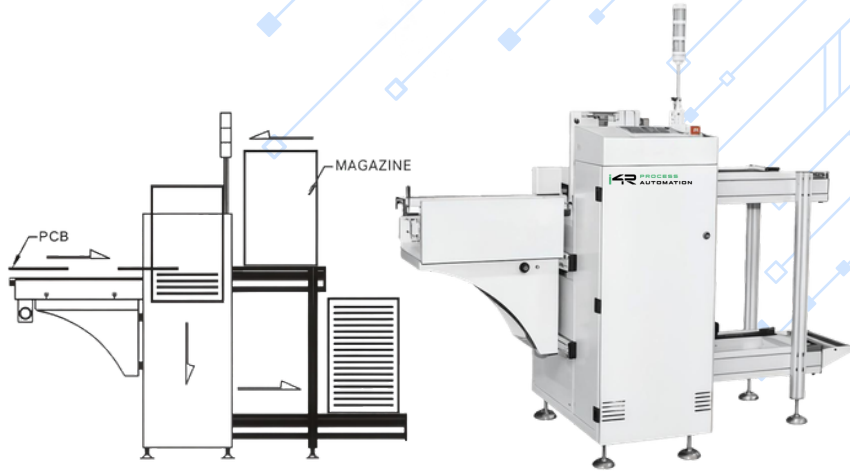

Magazine Unloader

Model	YL-250	YL-330	YL-390	YL-460A	YL-460B
Dimension(mm)	1272*773*1170	1360*853*1170	1587*988*1250	1612*1059*1250	2065*1230*1250
PCB Size(mm)	50*80-330*250	50*80-445*330	50*80-530*390	50*80-530*460	50*80-610*460
Rack Size(mm)	355*320*563	460*400*563	535*460*563	535*530*563	630*530*563
No. of Magazine	Upper:1, Lower:2				
Time Feed PCB	Board up for 8 seconds				
Magazine ReplacementTime	Approx.30 seconds or specify				
Indexing Pitch	10.20.30.40mm or specify				
Power Supply	AC 1P 110V/220V; Max 300VA				
Air Pressure	4- 6bar,10ltr/min Max				
Transport Height	900±20mm(or customized)				
Transport Direction	From left to right or right to left				
Weight(KG)	140	200	240	300	350

Model	YU-250	YU-330	YU-390	YU-460A	YU-460B
Dimension(mm)	1825*773*1170	2080*853*1170	2327*987*1250	2370*1059*1250	2610*1230*1250
PCB Size(mm)	80*80-330*250	80*80-445*330	80*80-530*390	80*80-530*460	80*80-610*460
Rack Size(mm)	355*320*563	460*400*563	535*460*563	535*530*563	630*530*563
No. of Magazine	Upper:1, Lower:2				
Time Feed PCB	Lower board for 10 seconds				
Magazine ReplacementTime	Approx.30 seconds or specify				
Indexing Pitch	10.20.30.40mm or specify				
Power Supply	AC 1P 110V/220V; Max 300VA				
Air Pressure	4- 6bar,10ltr/min Max				
Transport Height	900±20mm(or customized)				
Transport Direction	From left to right or right to left				
Weight(KG)	160	220	280	320	450

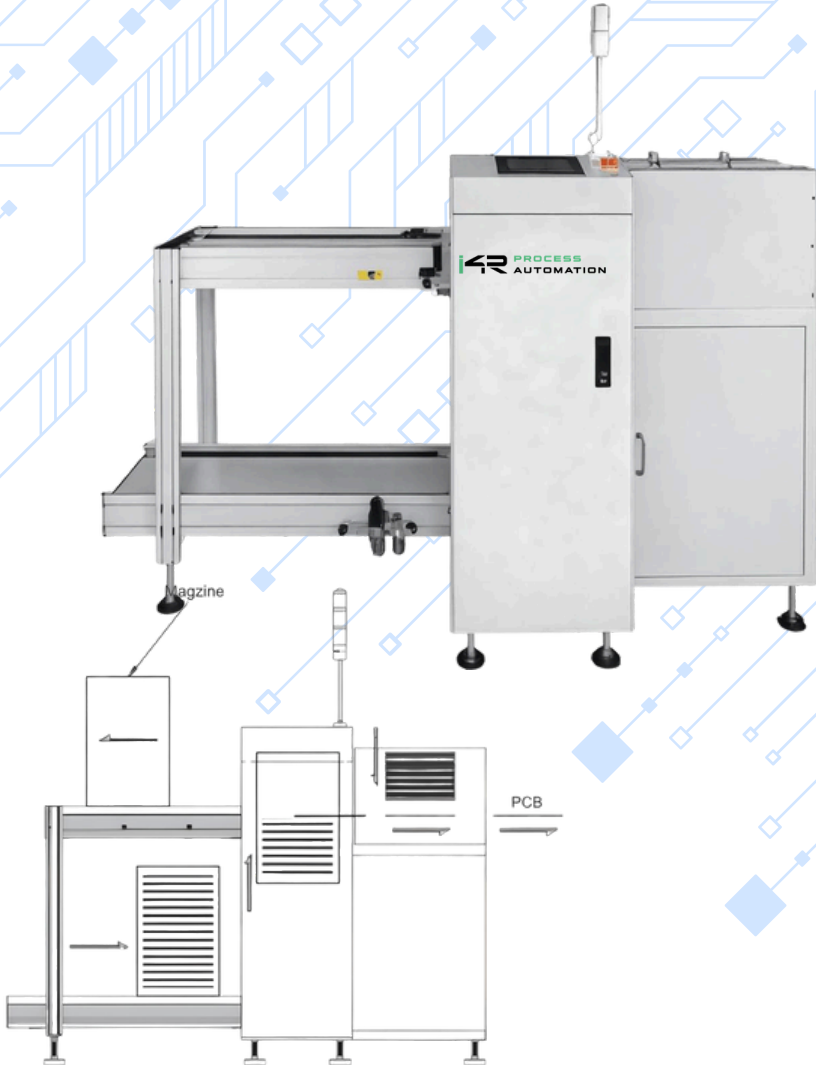

Model	YF-250	YF-330	YF-390
Dimension(mm)	1850*855*1250	2185*935*1250	2320*994*1250
PCB Size(mm)	50*80-330*250	50*80-445*330	50*80-460*390
Rack Size(mm)	355*320*563	460*400*563	535*460*563
No. of magazine	Upper Conveyor:1magazine; Lower Conveyor: 2magazine		
Indexing pitch	10 . 20 . 30 . 40mm or specify		
Maximum PCBs capacity	400pcs(0.6mm thick PCB)		
Cycle Time	Approx. 12 seconds or specify		
Power Supply	AC 1P 110V/220V; Max 300VA		
Air Pressure	4-6bar, 30ltr/min Max		
Transport Height	900±20mm(or customized)		
Transport Direction	From left to right or right to left		
Weight(KG)	190	220	260

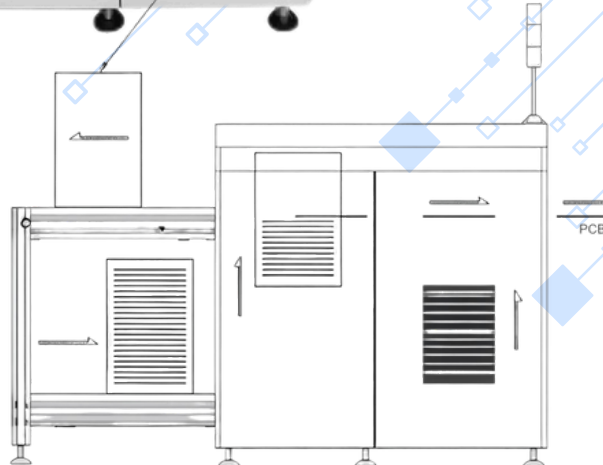

Model	YV-250	YV-330	YV-390	YV-460
Dimension(mm)	1800*865*1250	2220*945*1250	2450*1110*1250	2450*1250*1250
PCB Size(mm)	50*80-330*250	50*80-445*330	50*80-530*390	50*80-530*460
Rack Size(mm)	355*320*563	460*400*563	535*460*563	535*530*563
No. of Magazine	Upper Conveyor: 1magazine; Lower Conveyor: 2magazine			
Indexing Pitch	10 . 20 . 30 . 40mm or specify			
Maximum PCBs Capacity	400pcs(0.6mm thick PCB)			
Cycle Time	Approx. 12 seconds or specify			
Power Supply	AC 1P 110V/220V; Max 300VA			
Air Pressure	4-6bar, 30ltr/min Max			
Transport Height	900±20mm(or customized)			
Transport Direction	From left to right or right to left			
Weight(KG)	200	240	280	320



Model	YSU-460
Dimension(mm)	550*889*1200
PCB Size(mm)	50*50-530*460
Cycle Time	Approx. 10 seconds or specify
Maximum PCBs Capacity	400pcs(0.6mm thick PCB)
Power Supply	AC 1P 110V/220V; Max 100VA
Air Pressure	4-6bar, 10ltr/min Max
PCB Thickness	0.6mm Min
Transport Height	900±20mm(or customized)
Transport Direction	From left to right or right to left
Weight(KG)	200

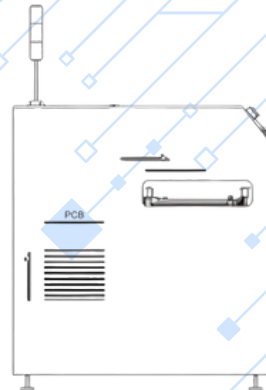
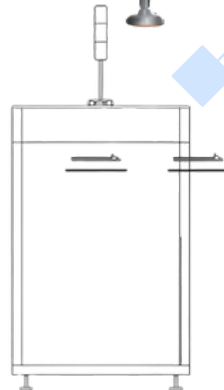

Model	YTS-460
Dimension(mm)	650*1200*1300
PCB Size(mm)	50*50-530*460
Maximum PCBs Capacity	400pcs(0.6mm thick PCB)
Cycle Time	Approx. 12 seconds or specify
Power Supply	AC 1P 110V/220V; Max150VA
Air Pressure	4-6bar,30ltr/min Max
Transport Height	900±20mm(or customized)
Transport Direction	From left to right or right to left
Weight(KG)	150



Model	YNO-250	YNO-330	YNO-390	YNO-460
Dimension(mm)	1800*1435*1250	2065*1690*1250	2330*1810*1250	2330*1950*1250
PCB Size(mm)	50*80-330*250	50*80-445*330	50*80-530*390	50*80-530*460
Rack Size(mm)	355*320*563	460*400*563	535*460*563	535*530*563
No. of Magazine	Upper Conveyor:1 magazine; Lower Conveyor:1 magazine			
Magazine Replacement Time	Approx.30 seconds or specify			
Indexing Pitch	10.20.30.40mm or specify			
Power Supply	AC 1P 110V/220V; Max 300VA			
Air Pressure	4-6bar,10ltr/min Max			
Transport Height	900±20mm(or customized)			
Transport Direction	From left to right or right to left			
Weight(KG)	310	340	370	400



Model	YDU-250	YDU-330	YDU-390	YDU-460
Dimension(mm)	1800*1435*1250	2065*1690*1250	2330*1810*1250	2330*1950*1250
PCB Size(mm)	80*80-330*250	80*80-445*330	80*80-530*390	80*80-530*460
Rack Size(mm)	355*320*563	460*400*563	535*460*563	535*530*563
No. of Magazine	Upper Conveyor:1 magazine; Lower Conveyor:1 magazine			
Magazine Replacement Time	Approx.30 seconds or specify			
Indexing Pitch	10.20.30.40mm or specify			
Power Supply	AC1P110V/220V; Max 300VA			
Air Pressure	4-6bar,10ltr/min Max			
Transport Height	900±20mm(or customized)			
Transport Direction	From left to right or right to left			
Weight(KG)	320	350	380	410



Model	YCL-250	YCL-330	YCL-390	YCL-460
Dimension(mm)	850*765*1250	1170*845*1250	1300*909*1250	1300*980*1250
PCB Size(mm)	50*80-330*250	50*80-445*330	50*80-530*390	50*80-530*460
Rack Size(mm)	355*320*563	460*400*563	535*460*563	535*530*563
No. of Magazine	Upper Conveyor:1 magazine; Lower Conveyor:1 magazine			
Time feed PCB	Seconds 8 Approx			
Magazine Replacement Time	Approx.30 seconds or specify			
Indexing Pitch	10.20.30.40mm or specify			
Power Supply	AC1P110V/220V; Max 300VA			
Air Pressure	4-6bar,10ltr/min Max			
Transport Height	900±20mm(or customized)			
Transport Direction	From left to right or right to left			
Weight(KG)	120	180	220	280

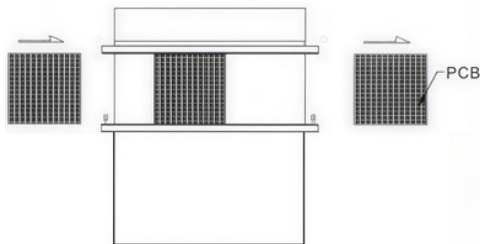

Model	YC-500	YC-600	YC-800	YC-1000	YC-1200	YC-1500	YC-2000	YC-2500
Dimension(mm)	500*850*920	600*850*920	800*850*920	1000*850*920	1200*850*920	1500*850*920	2000*850*920	2500*850*920
PCB Size(mm)	50*50-445*460							
Belt Type	Round Belt or Oblate Belt							
Conveying Speed	0.5-20M/min or customer specified							
Power Supply	AC 1P 110V/220V; Max 100VA							
Transport Height	900±20mm(or customized)							
Transport Direction	From left to right or right to left							
Weight(KG)	80	85	90	95	105	110	240	260
Optional(Please Check The Box If Needed)								
Width Adjustment 460								
Add LED Lights								
Two-stage								
Separate Width Adjustment Dual Segment								
Ordinary Dust Cover Without Glass								
Add Antistatic Glass Dust Cover								
PLC Control								
Tablet With Cooling Fan								
With Cooling Cover								
With Communication Function (not sold as a single unit)								
Add Computer Desktop								
Add Explosion-proof Lights								
Add Touch Screen								
Add Automatic Width Adjustment								

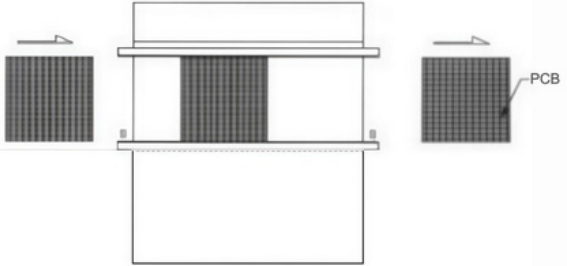

Model	YCR-500	YCR-600	YCR-800	YCR-1000	YCR-1200	YCR-1500	YCR-2000	YCR-2500
Dimension(mm)	500*718*920	600*718*920	800*718*920	1000*718*920	1200*718*920	1500*718*920	2000*718*920	2500*718*920
PCB Size(mm)	50*50-445*460							
Belt Type	Round Belt or Oblate Belt							
Conveying Speed	0.5-20M/min or customer specified							
Power Supply	AC 1P 110V/220V; Max 100VA							
Transport Height	900±20mm(or customized)							
Transport Direction	From left to right or right to left							
Weight(KG)	80	85	90	95	105	110	240	260
Optional(Please Check The Box If Needed)								
								
<input type="checkbox"/> Add LED Lights								
<input type="checkbox"/> PLC Control								
<input type="checkbox"/> Ordinary Dust Cover								
<input type="checkbox"/> Add Antistatic Glass Dust Cover								
<input type="checkbox"/> With Safety Protection								
<input type="checkbox"/> Tablet With Cooling Fan								
<input type="checkbox"/> With Cooling Cover								
<input type="checkbox"/> With Communication Function (not sold as a single unit)								
<input type="checkbox"/> Add Computer Desktop								
<input type="checkbox"/> Add Explosion-proof Lights								



Model	YIC-500	YIC-1000
Dimension(mm)	500*852*930	1000*852*930
PCB Size(mm)	50*50-460*460	50*50-460*460
Belt Type	Antistatic Oblate Belt	
Conveying Speed	0.5-20M/min or customer specified	
Power Supply	AC 1P 110V/220V; Max 100VA	
Transport Height	900±20mm(or customized)	
Transport Direction	From left to right or right to left	
Weight(KG)	75	90



Model	YDC-500	YDC-500 (With Lifting)	YDC-600	YDC-800	YDC-1000	YDC-1200	YDC-1500	YDC-2000	YDC-2500
Dimension(mm)	500*1050*920	500*1050*920	600*1050*920	800*1050*920	1000*1050*920	1200*1050*920	1500*1050*920	2000*1050*920	2500*1050*920
PCB Size(mm)	50*50*445*320								
Belt Type	Round Belt or Oblate Belt								
Conveying Speed	0.5-20M/min or customer specified								
Power Supply	AC 1P 110V/220V; Max 100VA								
Transport Height	900±20mm(or customized)								
Transport Direction	From left to right or right to left								
Weight(KG)	80	80	85	90	95	105	110	240	260
Optional(Please Check The Box If Needed)									
3-track Activities									
Add LED Lights									
Two-stage									
Separate Width Adjustment Dual Segment									
Ordinary Dust Cover									
Add Antistatic Glass Dust Cover									
PLC Control									
Tablet With Cooling Fan									
With Cooling Cover									
With Communication Function (not sold as a single unit)									
Add Computer Desktop									
Add Explosion-proof Lights									

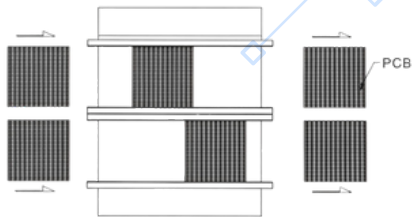

Solucinde HIGH END MULTIFUNCTIONAL VERTICAL TYPE BUFFER

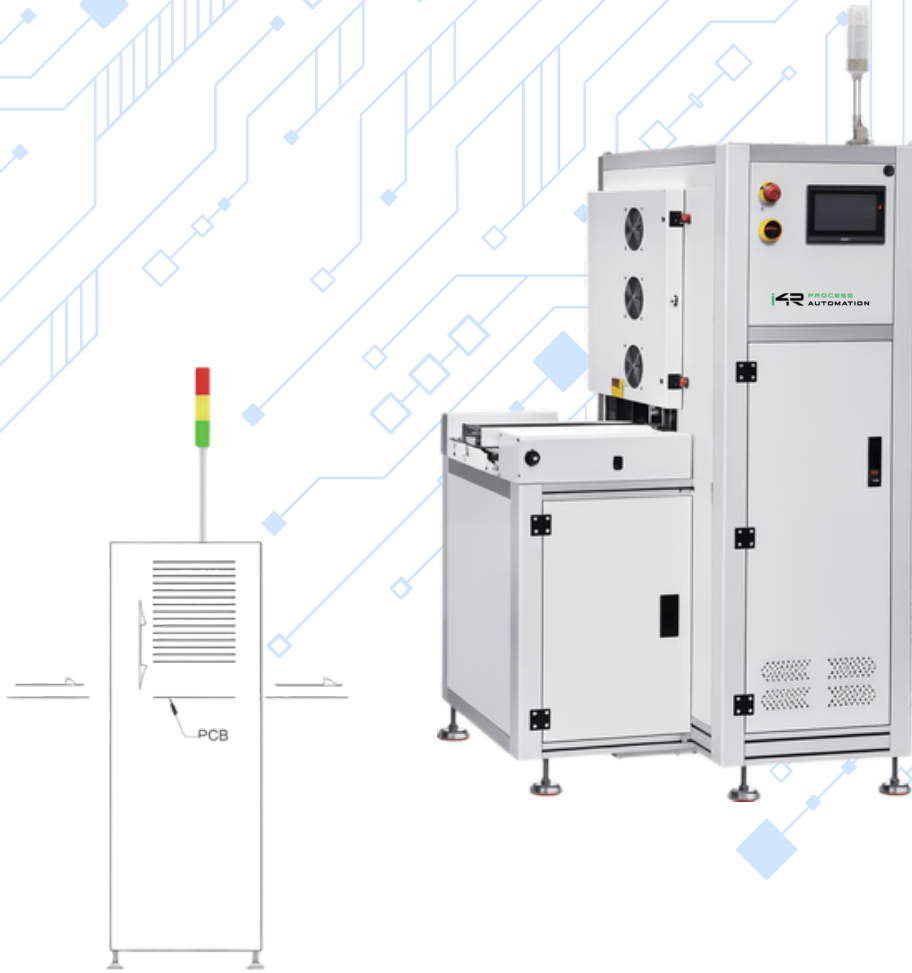

Model	YVB-350	YVB-460
Dimension(mm)	1000*790*1640	1200*900*1640
PCB Size(mm)	50*50-445*350	50*50-530*460
Cycle Time	Approx. 10 seconds	
Maximun PCBs Magazine	25pcs or specify	
Power Supply	AC 1P 110V/220V; Max 250VA	
Transport Height	900±20mm(or customized)	
Transport Direction	From left to right or right to left	
Weight(KG)	190	240
Optional(Please Check The Box If Needed)		
With Cooling Fan		
Add Ordinary Dust Cover Without Glass		
Add Antistatic Glass Dust Cover		
Add One Side To The Stretch		
Add Servo Motor		

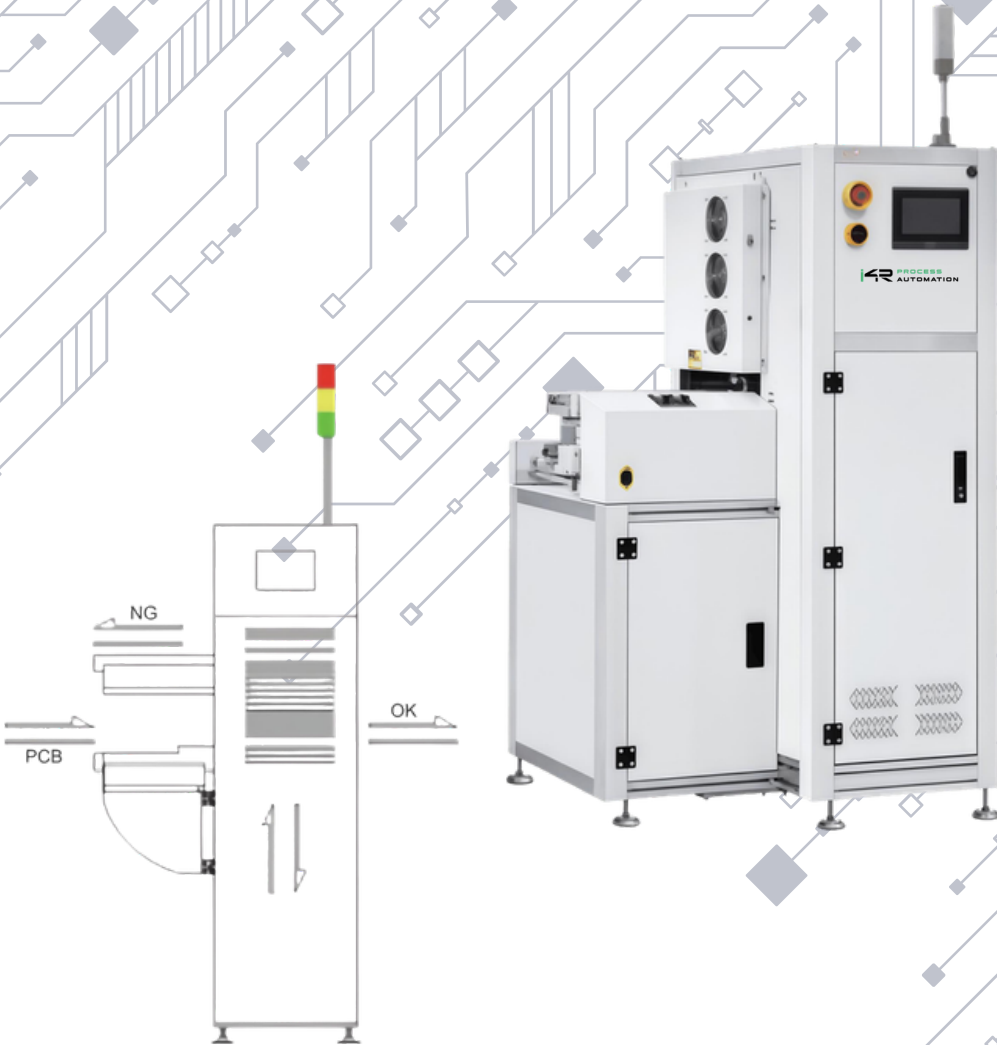

Model	YNC-350	YNC-460
Dimension(mm)	1000*790*1640	1200*900*1640
PCB Size(mm)	50*50-460*350	50*50-530*460
Cycle Time	Approx. 10 seconds	
Maximun PCBs Magazine	20pcs(or specify)	
Power Supply	AC 1P 110V/220V; Max 250VA	
Transport Height	900±20mm(or customized)	
Transport Direction	From left to right or right to left	
Weight(KG)	300	330
Optional(Please Check The Box If Needed)		
Add Ordinary Dust Cover Without Glass		
Add Antistatic Glass Dust Cover		
Add One Side To The Stretch		

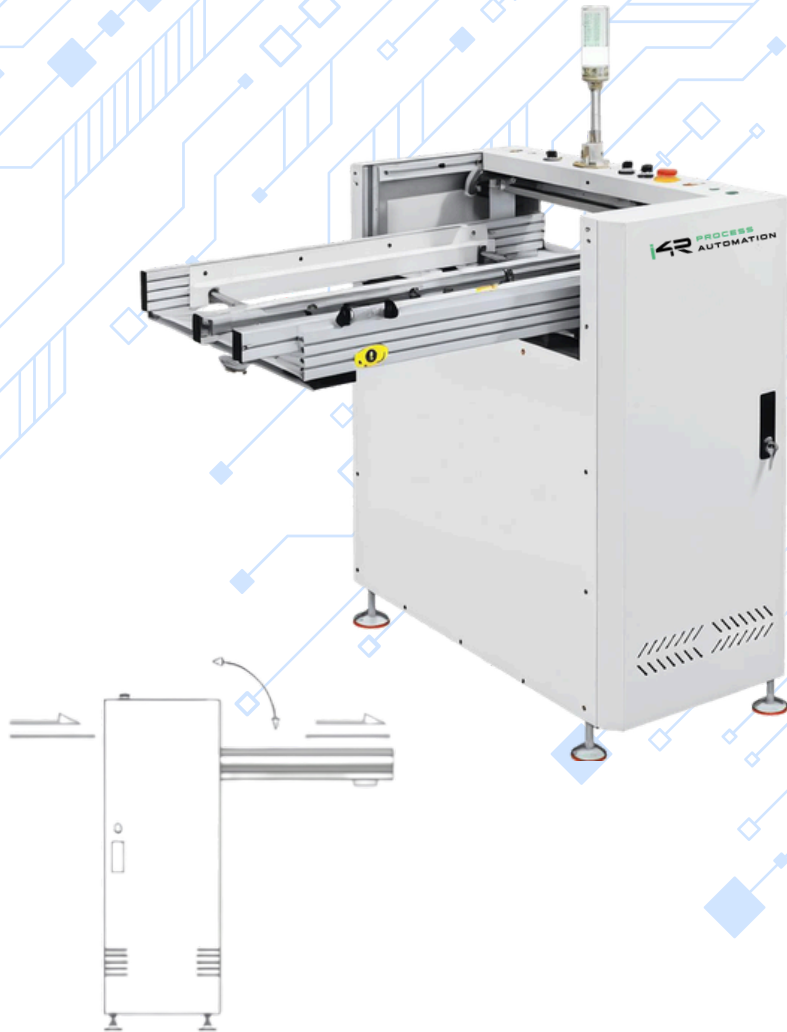

Model	YHC-350	YHC-460
Dimension(mm)	1000*730*1050	1000*860*1050
PCB Size(mm)	50*50-445*350	50*50-530*460
Belt Type	Oblate Belt	
Conveying Speed	0.5-20M/min or customer specified	
Power Supply	AC 1P 110V/220V; Max 100VA	
Air Pressure	4-6bar, 48ltr/min Max	
Transport Height	900±20mm(or customized)	
Transport Direction	From left to right or right to left	
Weight(KG)	180	200



Model	YDC-460
Dimension(mm)	1300*660*1050
PCB Size(mm)	50*50-530*460
Belt Type	Round Belt or Oblate Belt
Conveying Speed	0.5-20M/min or customer specified
Power Supply	AC 1P 110V/220V; Max 100VA
Air Pressure	4-6bar, 48ltr/min Max
Transport Height	900±20mm(or customized)
Transport Direction	From left to right or right to left
Weight(KG)	180

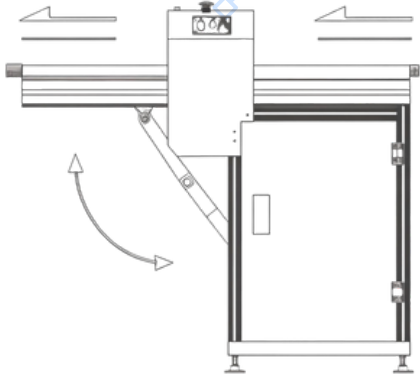

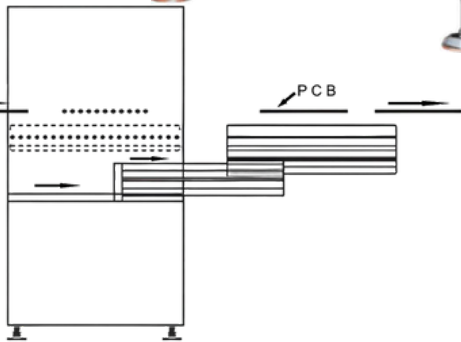

Model	YTC-350	YTC-460
Dimension(mm)	1500*650*1050	1500*760*1050
PCB Size(mm)	50*50-445*350	50*50-530*460
Belt Type	Oblate Belt	
Conveying Speed	0.5-20M/min or customer specified	
Power Supply	AC 1P 110V/220V; Max 200VA	
Transport Height	900±20mm(or customized)	
Transport Direction	From left to right or right to left	
Weight(KG)	200	230

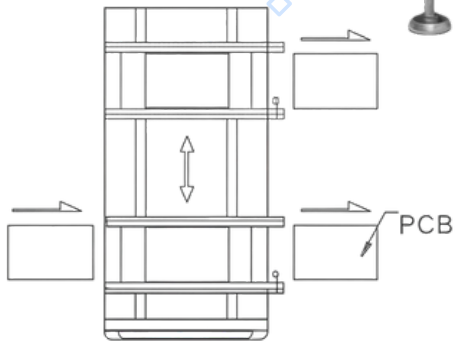

Model	YTC-330 (Single Station)	YTC-450A (Single Station)	YTC-450B (Double Stations)
Dimension(mm)	500*W*1050	500*W*1050	500*W*1050
Machine Width	(1000mm) Depends on traversing distance	(1500mm) Depends on traversing distance	(1500mm) Depends on traversing distance
PCB Size(mm)	50*50-330*350	50*50-450*350	50*50-450*350
Cycle Time	Depends on traversing distance		
Belt Type	Round Belt or Oblate Belt		
Power Supply	AC 1P 110V/220V; Max 250VA		
Transport Height	900±20mm(or customized)		
Transport Direction	From left to right or right to left		
Weight(KG)	120	140	140

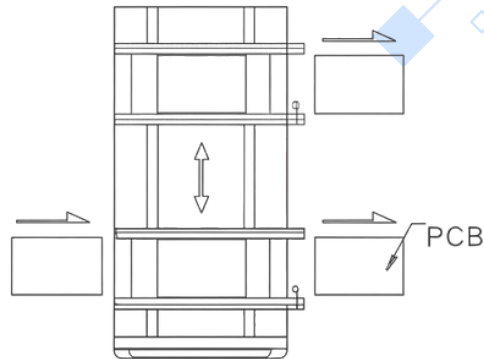

Model	YTC-390	YTC-550A (One side is fixed, the other side is movable)	YTC-550B (Activities on both sides)
Dimension(mm)	500*W*1050	600*W*1050	600*W*1050
Machine Width	(1200mm) Depends on traversing distance	(4500mm) Depends on traversing distance	(4500mm) Depends on traversing distance
PCB Size(mm)	50*50-390*350	50*50-550*350	50*50-550*350
Cycle Time	Depends on traversing distance		
Belt Type	Round Belt or Oblate Belt		
Power Supply	AC 1P 110V/220V; Max 250VA		
Transport Height	900±20mm(or customized)		
Transport Direction	From left to right or right to left		
Weight(KG)	130	280	280

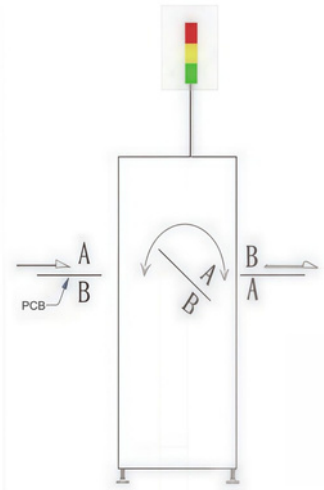

Model	YI-350	YI-460
Dimension(mm)	500*725*1250	600*856*1250
PCB Size(mm)	50*50-445*350	50*50-550*460
Cycle Time	Approx. 10 seconds	
Belt Type	Oblate Belt	
Power Supply	AC 1P 110V/220V; Max 150VA	
Air Pressure	4-6bar, 1.1ltr/min Max	
Transport Height	900±20mm(or customized)	
Transport Direction	From left to right or right to left	
Weight(KG)	120	160



Model	YT-350	YT-460
Dimension(mm)	600*600*1200	750*750*1200
PCB Size(mm)	50*50-400*350	50*50-530*460
Cycle Time	Approx. 15 seconds	
Belt Type	Round Belt or Oblate Belt	
Power Supply	AC 1P 110V/220V; Max 250VA	
Transport Height	900±20mm(or customized)	
Transport Direction	From left to right or right to left	
Weight(KG)	170	220



Model	YAE-350	YAE-460
Dimension(mm)	500*920*H	600*1050*H
Machine High	Depends on traversing distance	Depends on traversing distance
PCB Size(mm)	50*50-460*350	50*50-530*460
Cycle Time	Depends on lifting distance	
Belt Type	Round Belt or Oblate Belt	
Power Supply	AC 1P 110V/220V; Max 250VA	
Transport Direction	From left to right or right to left	
Weight(KG)	140	200

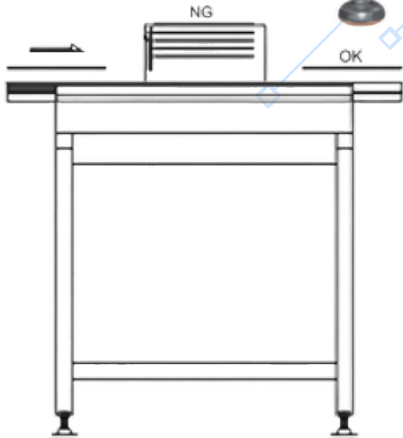

Model	YF-500	YF-600	YF-800	YF-1000
Dimension (mm)	500*793*900	600*793*900	800*793*900	1000*793*900
PCB Size(mm)	50*50-460*460	50*50-460*460	50*50-530*460	50*50-530*460
Belt Type	Antistatic Oblate Belt			
Conveying Speed	0.5-20M/min or customer specified			
Power Supply	AC 1P 110V/220V; Max 100VA			
Storage Plate Number&Distance	8pcs(or specify);20mm(or specify)			
Transport Height	900±20mm(or customized)			
Transport Direction	From left to right or right to left			
Weight(KG)	70	80	95	105



Model	YMB-250	YMB-330	YMB-390	YMB-460
Dimension(mm)	1150*1150*1250	1350*1350*1250	1550*1550*1250	1550*1780*1250
PCB Size(mm)	50*80-330*250	50*80-445*330	50*80-530*390	50*80-530*460
Rack Size(mm)	355*320*563	460*400*563	535*460*563	535*530*563
No. of Magazine	Upper Conveyor:1 magazine; Lower Conveyor:1 magazine			
Indexing pitch	10,20,30,40mm or specify			
Power Supply	AC 1P 110V/220V; Max 250VA			
Air Pressure	4-6bar, 15ltr/min Max			
Transport Height	900±20mm(or customized)			
Transport Direction	From left to right or right to left			
Weight(KG)	160	220	280	300

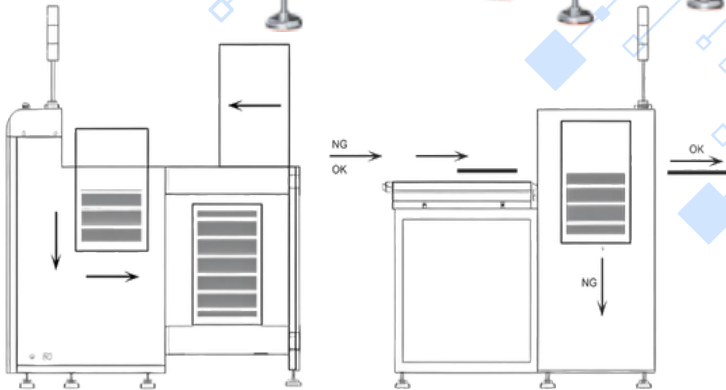



Model	YCM-460
Dimension(mm)	500*860*1114
PCB Size(mm)	50*50-530*460
Power Supply	AC 1P 110V/220V; Max 300VA
PCB thickness	0.6-5mm
Air pressure	4- 6bar, 10ltr/min Max
Transport Height	900±20mm(or customized)
Transport Direction	From left to right or right to left
Weight(KG)	100

Solucinde **WAVE SOLDERING UNLOADING MACHINE WITH TRACK**

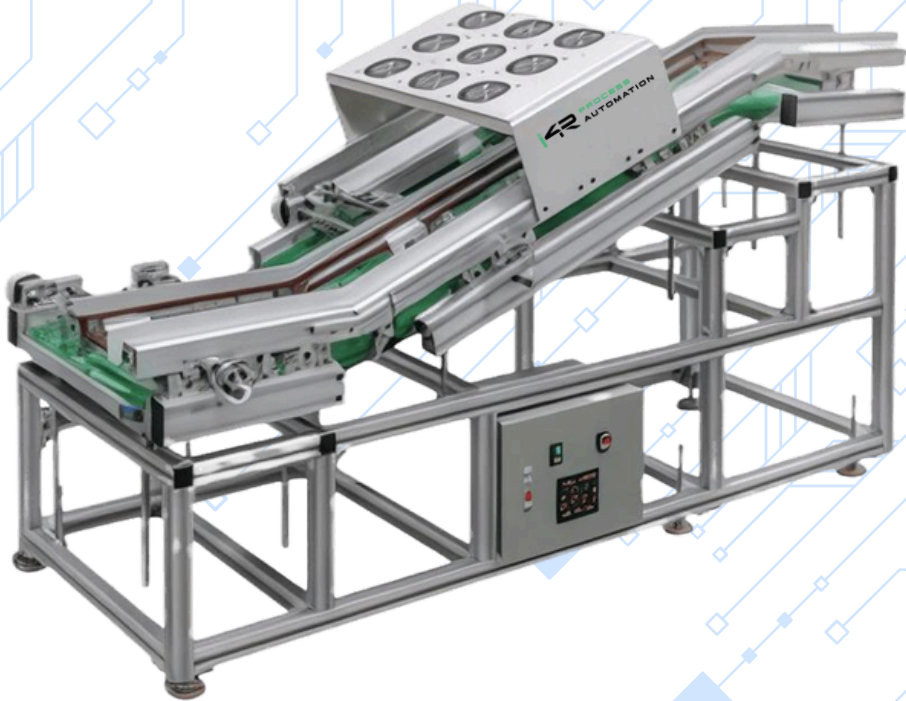

Model	YSU-350	YSU-450
Dimension(mm)	2200*485*1400	2200*600*1400
PCB Size(mm)	50*50-445*350	50*50-450*450
Speed	0-5m/min Adjustable	
Power Supply	AC 2P 110V/220V; Max 100VA	
PCB Thickness	0.6-5mm	
Transport Height	Input 1100-1350mm (Adjustable) Output 700-950 mm (Adjustable)	
Transport Direction	From left to right or right to left	
Weight(KG)	80	85

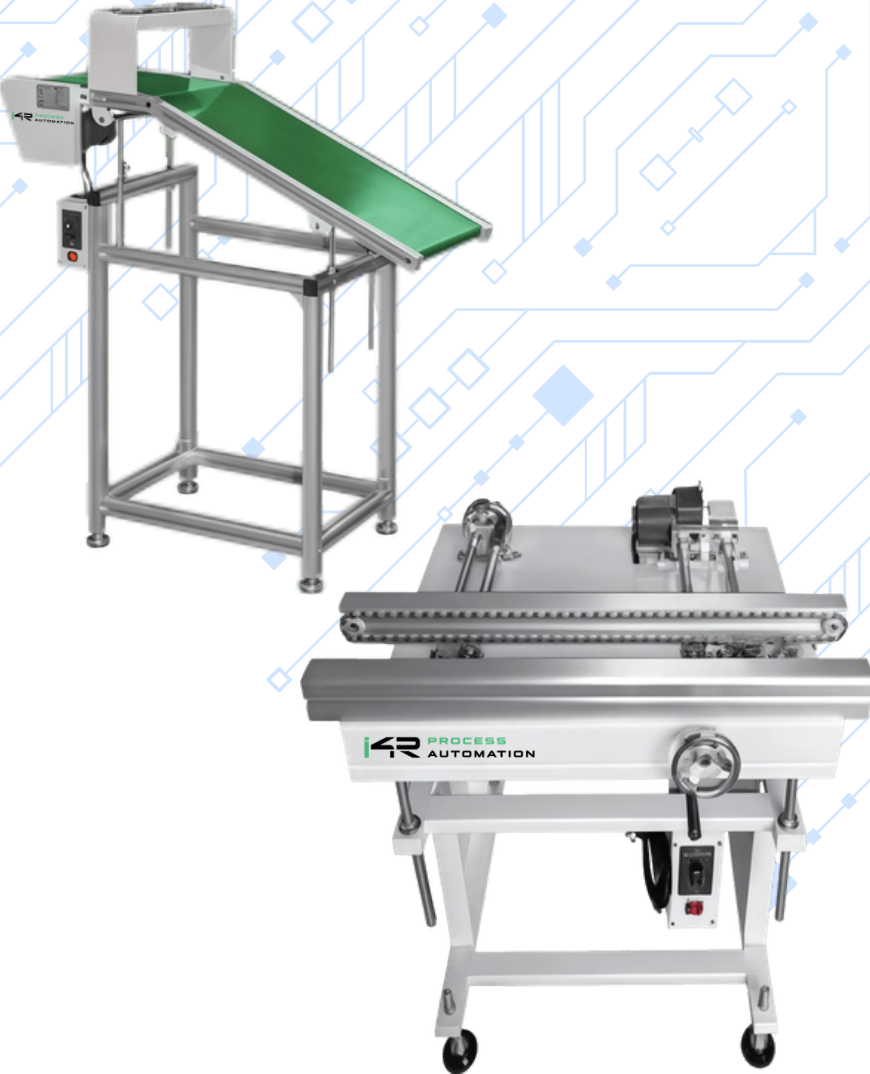

Model	YWU-350	YWU-460	YWD-350	YWD-460
Dimension(mm)	800*600*750	800*700*750	1200*520*1400	1200*620*1400
PCB Size(mm)	50*50-445*350	50*50-530*460	50*50-445*350	50*50-530*460
Conveying Speed	35B Nylon Chain or Specify 0.5 -20M/min or Customer Specified			
Power Supply	AC 1P 110V/220V; Max 100VA			
Transport Direction	From left to right or right to left			
Weight(KG)	35	45	35	45
Optional(Please Check The Box If Needed)				
Width Adjustment 460				
Add a Fan Cover				
With a Fan Below				

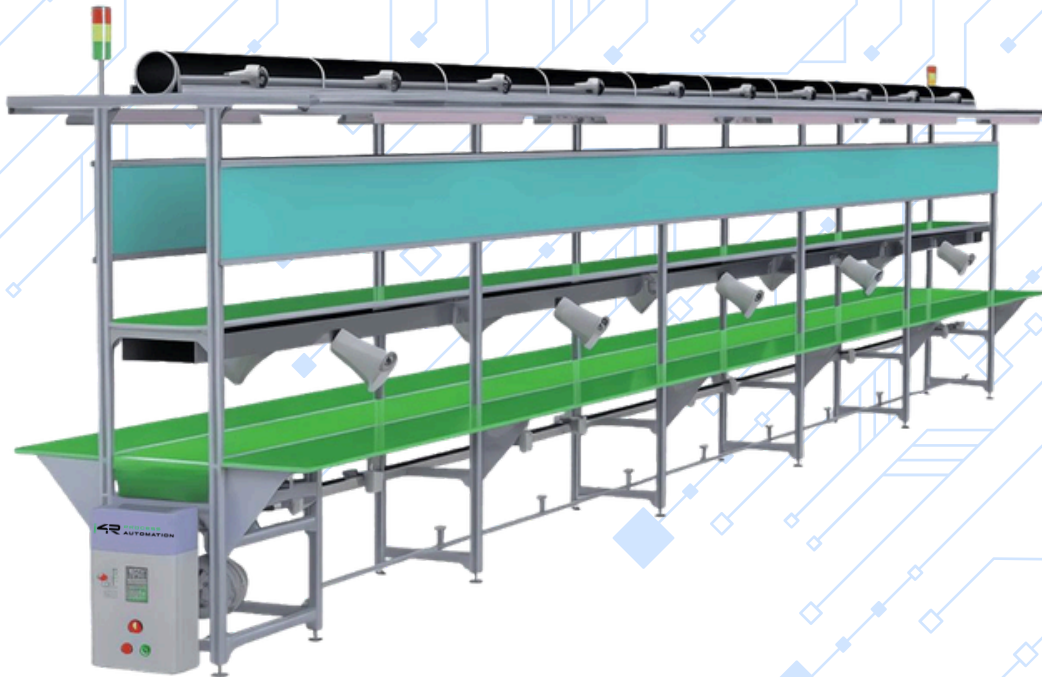

Item	Belt Conveyor Line(Standard)			
Length(m)	2	5	10	20
Aluminum Frame Thickness(mm)	1.5			
Belt Width(mm)	400			
Power Supply	Single-phase 220v or Three-phase 380v50Hz			
Speed	0.5m-20m/min(or customized)			
Weight(KG)				
Belt Conveyor Line Can Be Customized According To Customer Needs				
Optional(Please Check The Box If Needed)				
With Worktable(2mx0.8m with lights)				
With Worktable(1mx0.6m with lights)				
With Worktable(0.8mx0.6m without lights)				

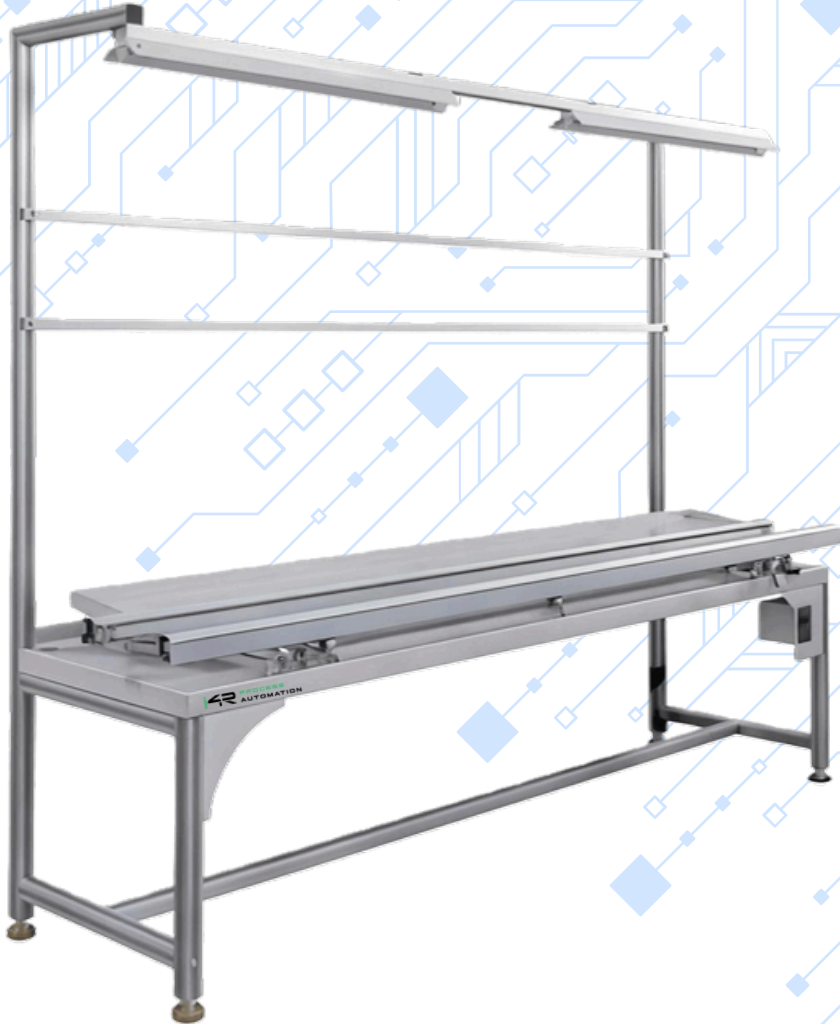

Item	Plug-in Conveyor Line(Standard)	
Length(m)	2.4	3
Power Supply	AC 1P 110V/220V; Max 250VA	
Weight(KG)		
Optional(Please Check The Box If Needed)		
	Width Adjustment 460	
	Add a Fan Cover	
	With a Fan Below	

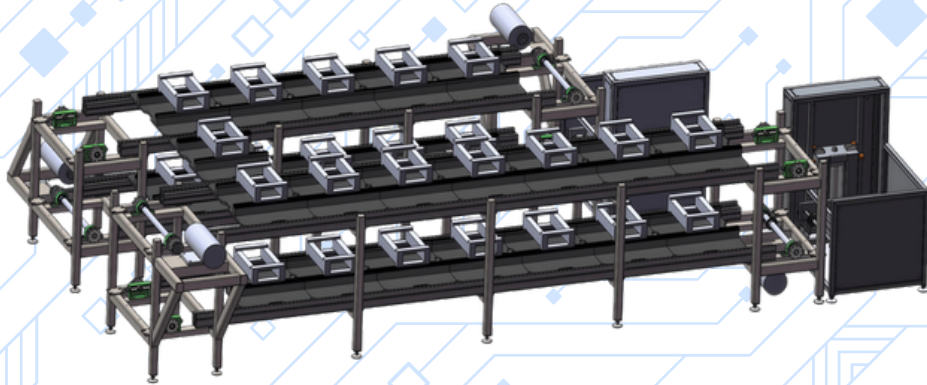

DOUBLE-SPEED CHAIN CONVEYOR



ROLLER CONVEYOR LINE

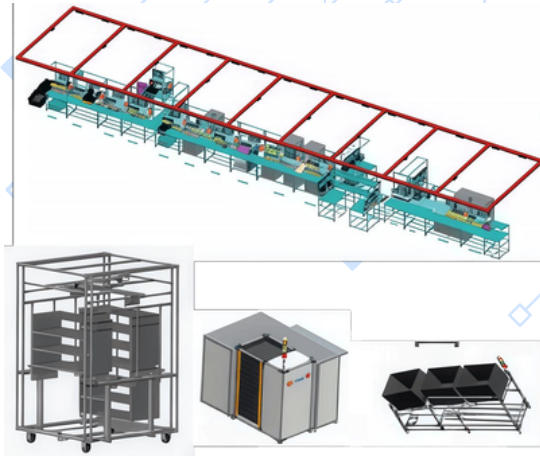

LEAN + LCIA PRODUCTION CONVEYOR LINE

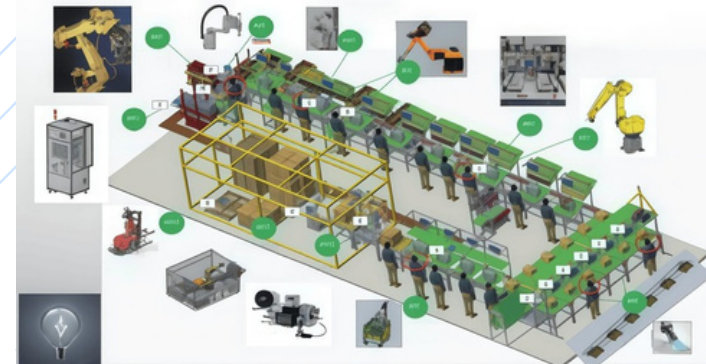

LEAN + AUTOMATED PRODUCTION CONVEYOR LINE

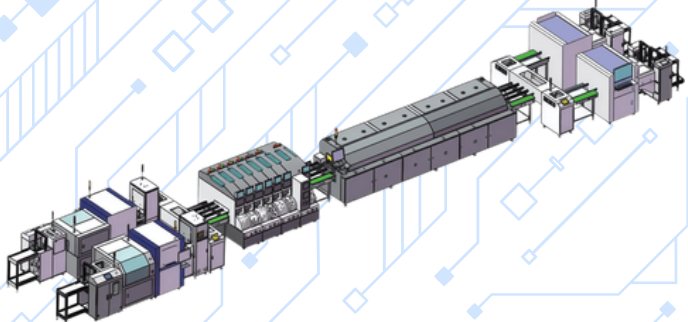

DUAL-TRACK HIGH-SPEED WIRING SCHEME A

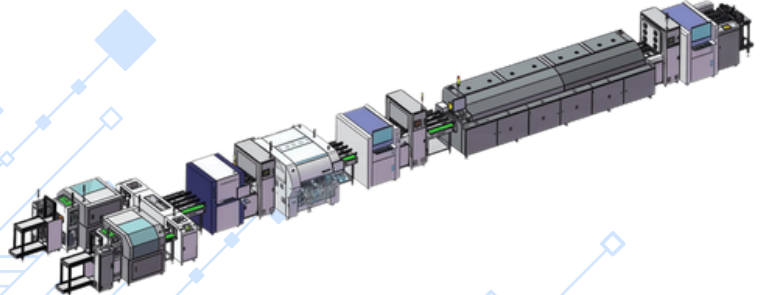

DUAL-TRACK HIGH-SPEED WIRING SCHEME B

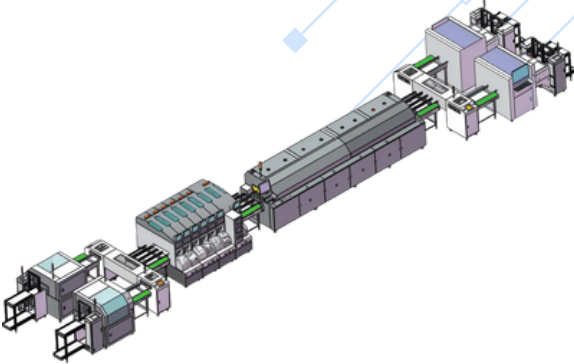

DUAL-TRACK WIRING SCHEME

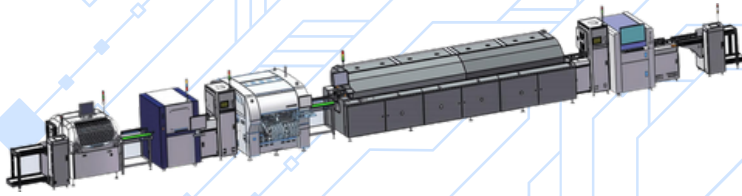

MONORAIL WIRING SCHEME

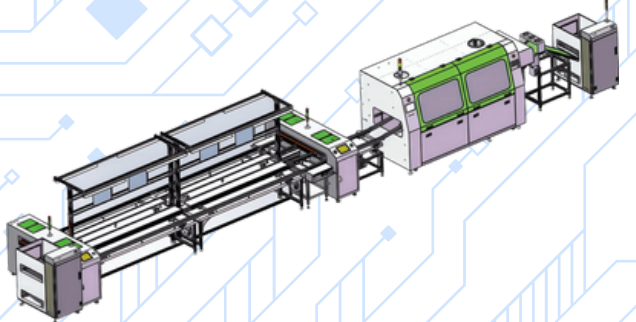

FIXTURE AUTOMATIC ROTATION WIRING SCHEME

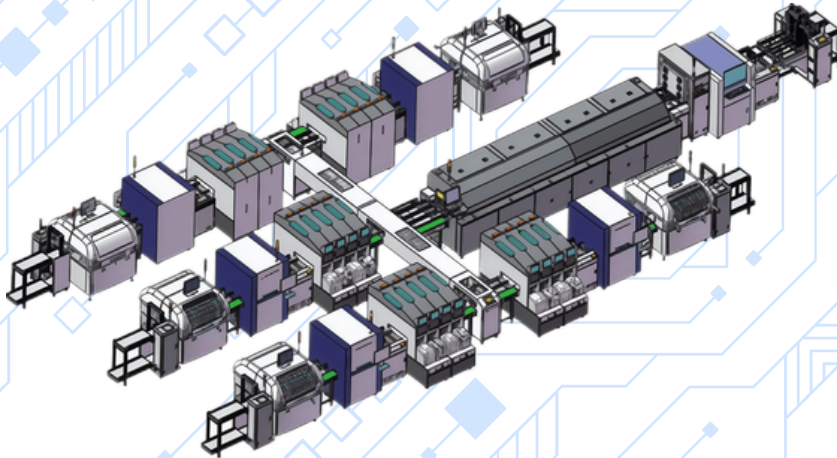

WIRING SCHEME OF MULTI-LINE INTO DUAL-TRACK REFLOW OVEN

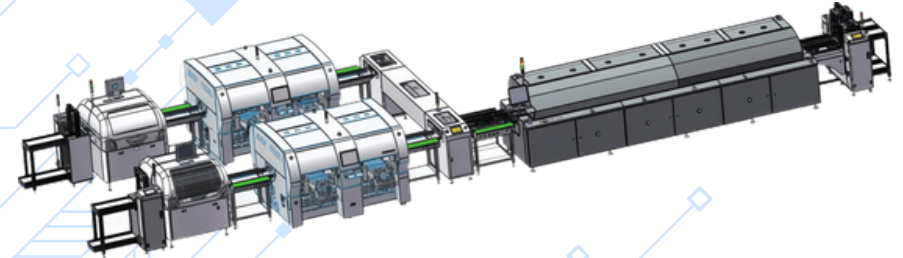

TWO-WIRE ENTRY DUAL-TRACK REFLOW OVEN TRANSLATION WIRING SCHEME

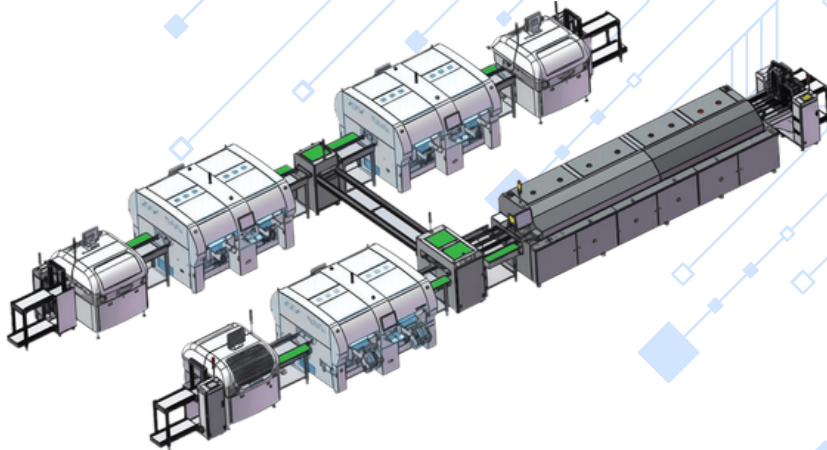

THREE-WIRE DOUBLE-TRACK REFLOW OVEN TURNTABLE WIRING SCHEME

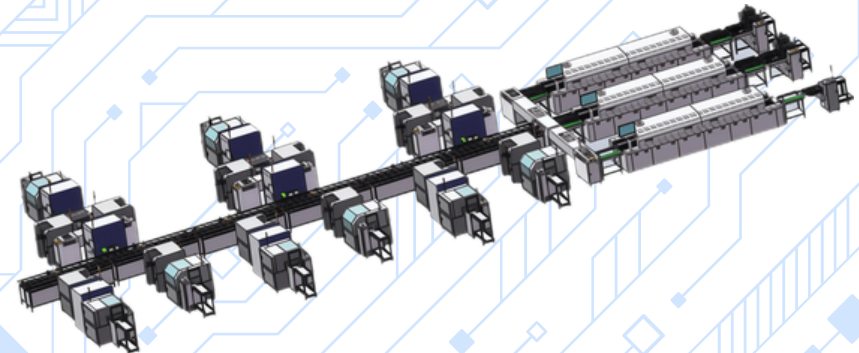

MULTI-WIRE MESH BELT REFLOW OVEN WIRING SCHEME

Model	YSI-A1250 Automatic Stencil Inspection Machine	YSI-S1360 Semi-Automatic Stencil Inspection Machine	Manual Stencil Inspection Machine	YS-A920 Automatic Scraper Inspection Machine	YS-S610 Semi-Automatic Stencil Inspection Machine	Manual Scraper Inspection Machine
						

Model

D1200 high-end Stencil Inspection Machine

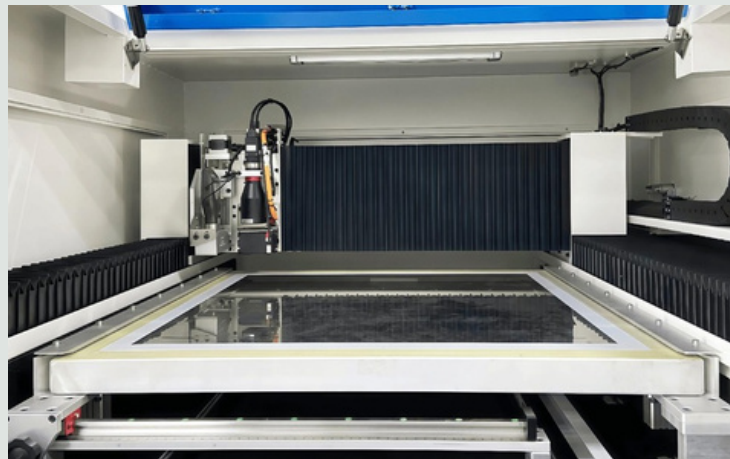

YSI-A1250 AUTOMATIC STENCIL INSPECTION MACHINE



YSI-A1250 Automatic Stencil Inspection Machine is a high-precision inspection equipment dedicated for cleaned stencil after printing. The main purpose is to control the quality of cleaned stencil. Utilizes the automatic image measurement technology to scan the standard stencil image and collects parameters such as tension, and then compares it with the cleaned stencil to determine whether the cleaned stencil is qualified within the set error range. At the same time, it automatically records and uploads the stencil cleaning inspection results to optimize the quality of the stencil and realize the automatic management of the information chain. This equipment makes up for the defects of low efficiency, poor quality, inability to manage and trace data, and inability to improve the process of manual inspection, and provides an important reference for the improvement and control of printing process.

Model name:YSI-1250

Inspection Types:Blocking hole, foreign body, tension, glitch

Tension TestHighprecision tension meter, Multi position test freely; accuracy: $\pm 1\text{N/cm}$, tension range: 0–50N

Min. Inspection:80 μm *80 μm

Camera: 20 million

Lens: 12MM 1/4" lens

Bottom light:WhiteLED light source

FOV size:250mm*190 mm

Stencil frame:Support 736 \times 736 mm below

Max. inspect range:600 \times 600 mm

Appearance (L \times W \times H) : 1680 * 1250 * 1750 mm

Weight: 800 KG

New Template:Standard image template set up

Set up time: 2–3 minutes

Test mode: Off line testing

Template data:Transfertemplate image to process

User authority:Dividetooperator and tester

QR code:StandardQRcode management function

Searching:Thecleantimes and inspect time can be searched

Voltage:AC220V $\pm 10\%$ (single phase), 50/60Hz

Air pressure: 0.8 MPA

TYPE	FUNCTION NAME	FUNCTION EXPLANATION
Inspection Function	Mesh hole test of stencil	Hold blocking, foreign body, tension, glitch
	Auto tension test	High precision tension meter, five points test, accuracy: $\pm 1\text{N/cm}$, tension range: 0–50N
Software Function	Stencil information management system	Inspect the stencil whether is cleaned thoroughly. Test the mesh tension whether is over limited.
	Stencil QR code scan information management	Quick check the data of the cleaned stencil through QR Code Scan.
	MES Data Connect Upload (optional)	MES Data Upload and data Management System

YSI-S1360 SEMI-AUTOMATIC STENCIL INSPECTION MACHINE

Solucinde YSI-S1360 Semi-Automatic Stencil Inspection Machine



Semi-Automatic
Stencil Inspection Machine YSI-S1360



Manual Stencil
Inspection Machine

Model name: YSI-S1360

Inspection Types: Blocking hole, foreign body, tension, glitch

Tension Test: High accuracy, Multi position test freely, accuracy: $\pm 1\text{N/cm}$, tension range: 0–50N

Camera: 20 million

FOV size: 20mm * 10mm

Lens: 50mm

Stencil frame: Support 736 × 736 × 60cm below

Appearance (L × W × H) : L1770 * W1360 * H1790 mm

Weight: 500 KG

TYPE	FUNCTION NAME	FUNCTION EXPLANATION
Inspection Function	Mesh hole test of stencil	Hold blocking, foreign body, tension, glitch (Judging by eye)
	Auto tension test	High precision tension meter, five points test, Accuracy: $\pm 1\text{N/cm}$, tension range: 0–50N
Software Function	Stencil information management system	Inspect the stencil whether is cleaned thoroughly. Test the mesh tension whether is over limited.
	Stencil QR code scan information management	Quick check the data of the cleaned stencil through QR Code Scan.
	MES Data Connect Upload (optional)	MES Data Upload and data Management System

YS-A920 THE PRESSURE OF SCRAPER CAN BE AUTOMATICALLY CONTROLLED

YS-A920 The Pressure Of Scraper Can Be Automatically Controlled



The fully automatic scraper inspection machine is a high-precision inspection equipment dedicated to the quality inspection of scrapers for SMT solder paste printers. This equipment uses a PC motion control card control mode, combined with a high-definition industrial camera + backlight source, to automatically detect the straightness, edge wear, surface defects and flatness of the scraper to ensure that the scraper quality meets production standards. The equipment requires manual placement of the scraper and is equipped with a barcode scanner to quickly enter the scraper code for data traceability. The operator can perform basic control through the PC interface, and conduct detailed analysis, storage and export of inspection data to link to the MES system.

Model Number: YS-A920

Control Method: motioncontrolling board card

Inspection Method: Labor placement + visual inspection (Industrial camera + backlight source)

Squeegee Length:100mm – 600mm (can be customized)

Measure Platform: 000grade marble platform, ensure measure accuracy

Measure Accuracy: $\pm 0.01\text{mm}$ (Includes flatness/Linearity inspection)

Optics System: HDIndustrial camera, 12 Megapixel above

Light System: Highbrightness LED light source

Pressure Control: Thepressure of scraper can be automatically controlled

Data Storage: Detectiondata can be stored on PC and data export is supported

Scan Function: Equippedwith a barcode scanner, it can quickly input the scraper code to achieve data traceability

MES Connection: Available

Power: AC 220V, 50/60Hz

Equipment Dimension: L1250mm * W920mm * H1650mm

Equipment Weight: 180KG

YS-S610 SEMI-AUTOMATIC SCRAPER INSPECTION MACHINE

Solucinde YS-S610 Semi-Automatic Scraper Inspection Machine



Semi-Automatic Scraper Inspection Machine
Model Type: YS-S610



Manual Scraper Inspection Machine

The semi-automatic scraper inspection machine is a device used to detect the quality of SMT printing machine scrapers. It mainly evaluates key parameters such as scraper straightness, wear, and edge integrity. This equipment uses a 00-grade marble platform to provide a high stability and precise scraper placement environment. The LED backlight brightness and scraper pressure are controlled by PLC + touch screen, providing more intuitive detection assistance for manual visual inspection, improving detection efficiency and accuracy.



Solucinde **YS-S610 Semi-Automatic Scraper Inspection Machine**

Equipment technical parameters	
Equipment model	YS-S610
Applicable scraper length	100mm – 600mm
Detection method	Artificial visual inspection (assisted by high-brightness LED backlight)
Measuring platform	00-grade marble table, high flatness, strong stability, reducing human errors
Backlight system	High-brightness LED light source, adjustable brightness, improve scraper edge visibility
Pressure control	PLC control, adjustable scraper pressure, simulate the actual printing machine scraper force
Operation interface	10.3 inch touch screen, adjustable backlight brightness, pressure and other parameters
Control system	PLC and touch screen control system to ensure the stability of detection parameters
Data management	Supports detection record archiving, detection data can be manually input and exported
Communication interface	USB, LAN, RS232 (optional)
MES	Can be connected to MES system
Power requirements	AC 220V, 50/60Hz
Equipment size	L750mm * W610mm * H1350mm
Equipment weight	180kg

SMT STENCIL CLEAN-INSPECTION-STORAGE MANAGEMENT SYSTEM

System Description

The SMT Stencil Cleaning, Inspection, and Storage Management System is an intelligent solution designed for the full lifecycle management of stencils in the electronics manufacturing industry.

Through modules such as automatic cleaning machines, stencil inspection machines, and intelligent stencil storage cabinets, the system enables automated cleaning, cleanliness and tension inspection, standardized storage, and full-process traceability for stencils.

Centered around the stencil inspection machine database, the system centrally stores and manages data from all stages while integrating critical production data with the MES system. This enables transparent, standardized, and intelligent management of stencil usage.

The Whole Working Process

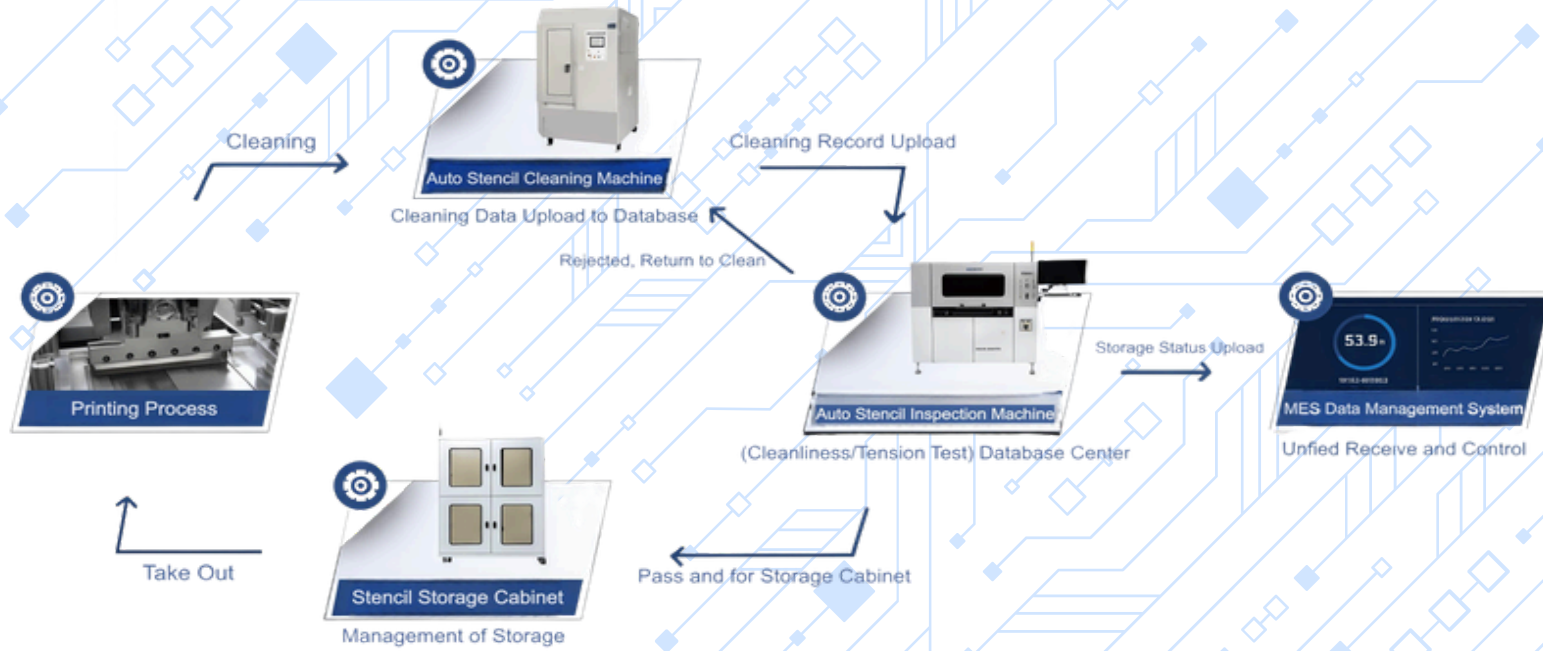

Feature

- **Unified Data Center:** Centralized management of the entire process data for cleaning, inspection, and storage of stencils via the inspection machine database, preventing data fragmentation and omission.
- **Cleanliness and Tension Assurance:** Ensures stencils meet process requirements before deployment, reducing printing defect rates.
- **Intelligent Access:** Automates stencil inbound/outbound processes via QR code scanning or MES commands, minimizing manual management errors.
- **Full Process Traceability:** Complete records from cleaning, inspection, storage to usage are readily accessible, meeting quality management and audit requirements.
- **Seamless MES Integration and Connection:** Real-time upload of critical data supports production scheduling, foolproof management, and anomaly analysis.

SMT SCRAPER CLEAN-INSPECTION-STORAGE MANAGEMENT SYSTEM

System Description

The SMT scraper cleaning, inspection, and storage management system is an intelligent solution designed for the full life cycle management of printing press scraper.

Through modules including automatic scraper washers, scraper inspection machines, and intelligent scraper storage cabinets, the system enables automated cleaning, cleanliness and edge inspection, standardized storage, and full-process traceability.

Centered around the scraper inspection machine database, the system centrally stores and manages data from all stages. It interfaces with the MES system to upload information, achieving traceable, standardized, and intelligent management of scraper usage.



Feature

- **Unified Database:**The inspection machine serves as a data hub, centrally managing data throughout the entire process of cleaning, inspection, and storage.
- **Quality Assurance:**Ensures scrapers are in optimal condition before use through flatness and edge inspections, reducing printing defect rates.
- **SmartAccess:**Automates blade inventory management via QR scanning or MES commands, minimizing human error.
- **Full-Process Traceability:**Complete information—from cleaning and inspection to storage and usage—is instantly accessible for quality control and audit requirements.
- **Seamless MES Integration and connection:**Real-time upload of critical data supports digital production and smart factory development.

Stencil Inspection Machine D1200



- ü Automatically detects area, location, foreign objects, presence of holes, and tension;
- ü High detection accuracy and wide detection range; Imports GERBER data with a modular data structure, allowing for immediate detection and result viewing within 2-3 minutes;
- ü Measures parameters such as stencil opening size and location, sets error ranges, and compares results with reference values to determine compliance;
- ü Simple and quick operation;
- ü Detection items:
Detection of hole defects such as opening deviation, opening accuracy, shape, excess holes, insufficient holes, area error, and edge burrs.

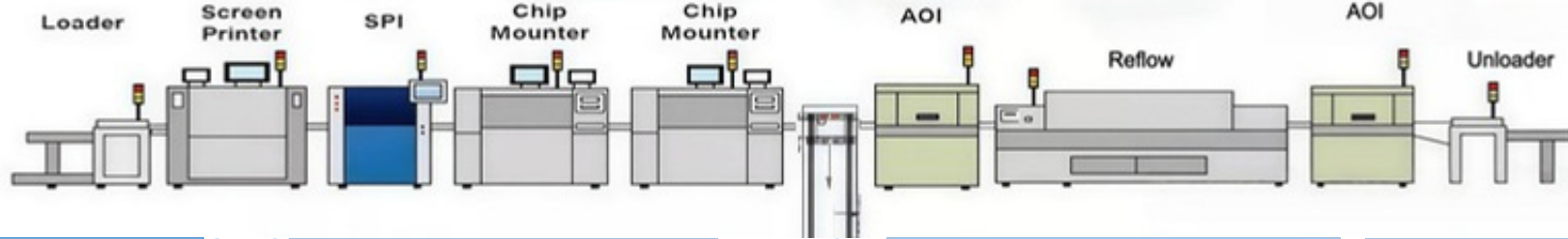

Solder paste/adhesive transfer is achieved through stencil printing with an open stencil

Solder paste inspection is performed, with real-time monitoring and timely adjustment of printing parameters

Component placement inspection is also performed, with real-time monitoring and timely adjustment of placement parameters

Reflow soldering inspection is performed, with real-time monitoring and timely adjustment of reflow soldering parameters

★ Approximately 75% of soldering problems are caused by poor solder paste printing:
 1. Stencil issues; 2. Squeegee issues; 3. Printing equipment issues; 4. Solder paste issues

Print

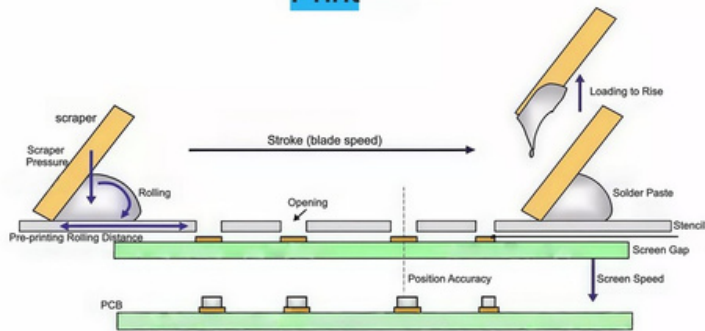

Improve Solder Paste Printing Quality



Printing Defects

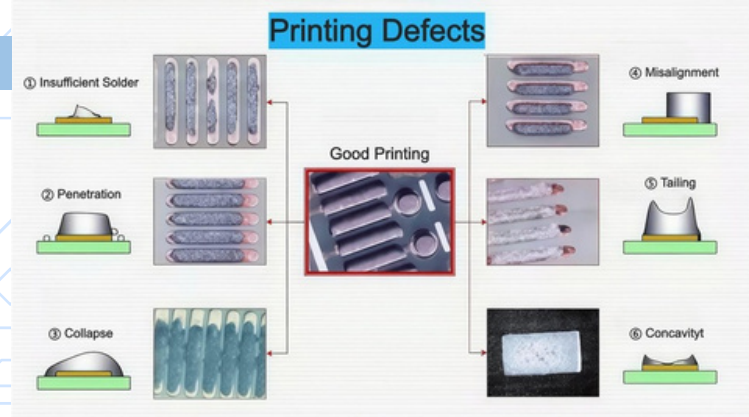

How to Verify the Working Condition of the Stencil?

SMT Stencil Influencing Factors:

Design aspects:
 Stencil thickness and aperture size, aperture shape, aperture inner wall condition, and other related factors.
 Maintenance aspects:
 Stencil cleanliness and tension level (requiring effective monitoring and management).

Trends in the Development of SMT Components:

Miniaturization and high-density assembly
 (Higher inspection accuracy requirements)

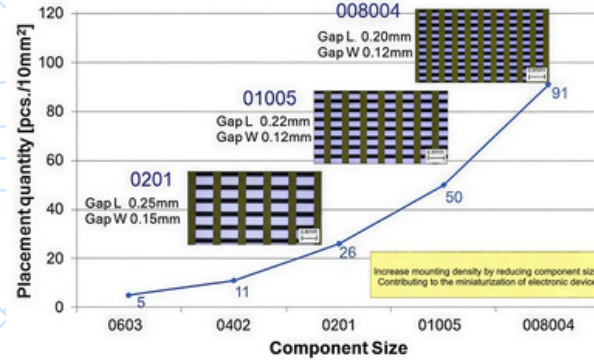

Figure: Other solder ball prevention methods

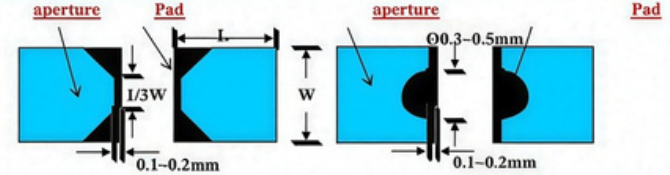

Figure: Opening Methods for 0402 Components & BGA



0402 chip: If the pad size is larger than 0.76 × 0.635 mm, first shrink it by 90% and then reshape it into an oval.
 uBGA pitch 0.8 mm: The pad is circular with a diameter of 0.33 mm. For square pads, size 0.33 × 0.33 mm with 0.05 mm chamfer.

Traditional SMT Stencil Manual Visual Inspection:

High workload, with efficiency and accuracy difficult to guarantee
 (Aperture precision and quality cannot be quantified)

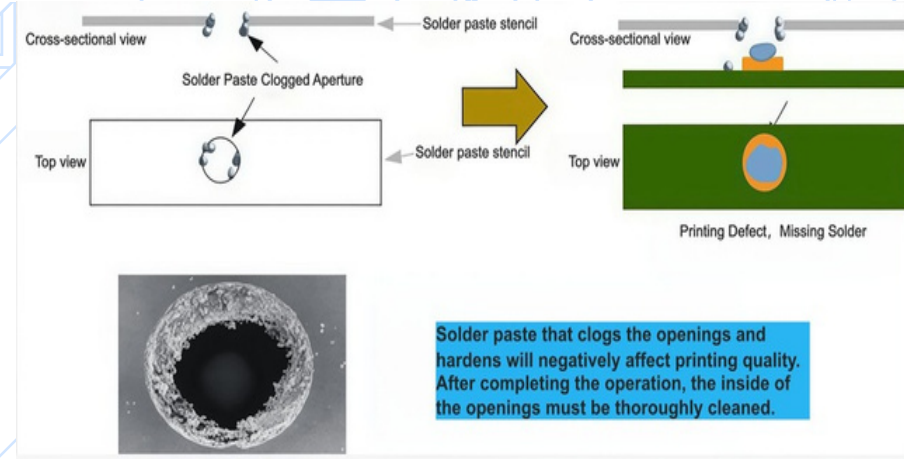

Machine vision inspection is imperative.

Cross-sectional view, Top view, Solder paste stencil, Solder Paste Clogged Aperture, Printing Defect, Missing Solder

Solder paste that clogs the openings and hardens will negatively affect printing quality. After completing the operation, the inside of the openings must be thoroughly cleaned.

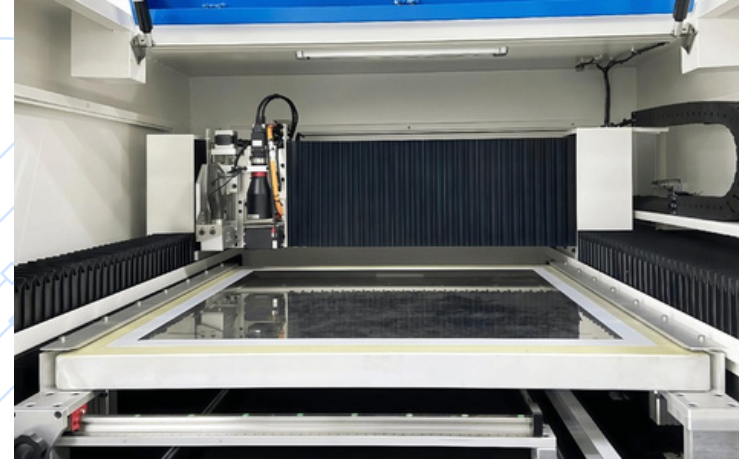

Disadvantages of Traditional Inspection

Currently, in stencil mold processing factories, data processing is performed using traditional methods: several specialized personnel are required to handle the customer's stencil data. Since each stencil contains a large amount of information, staff must carefully modify the apertures for each component. This can easily lead to fatigue and overwork, reducing efficiency and even causing errors in data processing.

The stencil inspection machine software is developed based on the CircuitCAM7 Pro data processing platform. It offers powerful data processing capabilities and excellent traceability of inspection results.

Currently, in SMT stencil processing, most stencils are produced using LKPF stencil cutting machines, which are typically equipped with CircuitCAM4 or CircuitCAM6 data processing software. Our company uses CircuitCAM7, which is an upgraded version of these platforms.

Efficient and reliable data processing, combined with professional process design standards, enables the detection of design errors at the source.

The latest version of CircuitCAM7 Pro combines library functions, geometric operations, and a user-friendly interface, effectively providing features of automated data processing. For example: it allows one-click output of multiple file types without being affected by closed layers; imported CAD window ratios are directly multiplied or divided to improve efficiency. The software supports composite processing of Chip components and other package patterns, enabling pre-set shape modifications regardless of complexity, streamlining the workflow. It automatically detects multiple or missing apertures, eliminating concerns about errors or omissions. Based on DRC results, it can automatically add pad data without manual modifications. Coordinate movement, rotation memory, and area calculation memory reduce repetitive input. Customizable shortcut keys, data browsing, viewing, and positioning functions make operations convenient and practical, with many additional features.

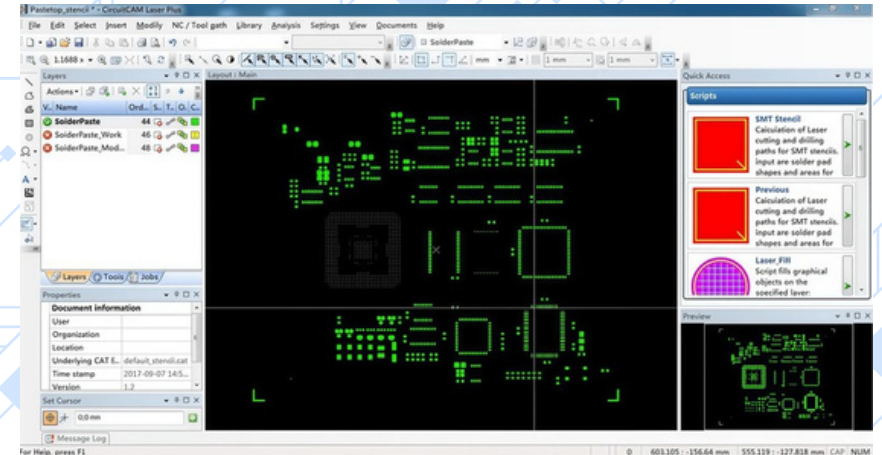
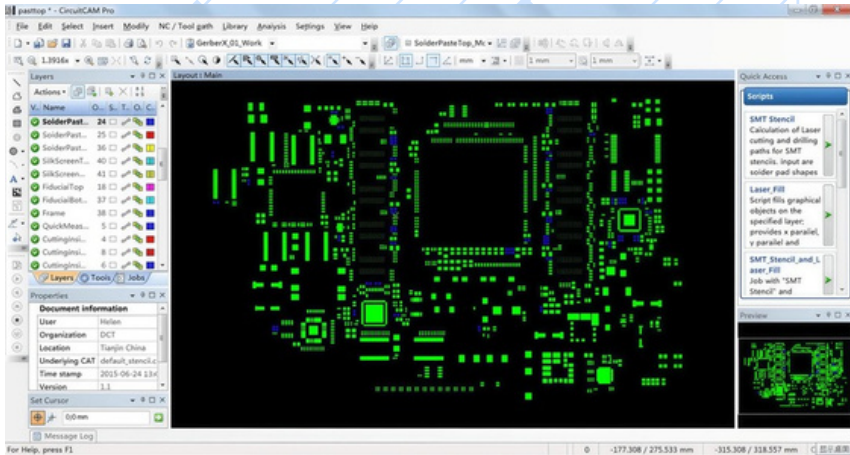

It can directly compare PCB and stencil GERBER data to verify the correctness of stencil design.

✓ TopLayer	31	
✓ Fiducial	104	
✓ PCB example.gbr	105	
✓ stencil example.gbr	106	
✓ SolderPasteTop_ 1 missing on 2	107	
✓ SolderPasteTop_ 2 missing on 1	108	
✓ SolderPasteTop_ 1 has several on...	109	
✓ SolderPasteTop_ 2 has several on...	110	
✓ SolderPasteTop_ both has several	111	

- 1 missing on 2 (2 is missing elements) 2 missing on 1 (1 is missing elements)
- 1 appears in 2 as several parts (elements in 1 are divided into multiple parts in 2)
- 2 appears in 1 as several parts (elements in 2 are divided into multiple parts in 1)
- Elements in layer 1 are split into multiple parts in layer 2, and elements in layer 2 are split into multiple parts in layer 1.

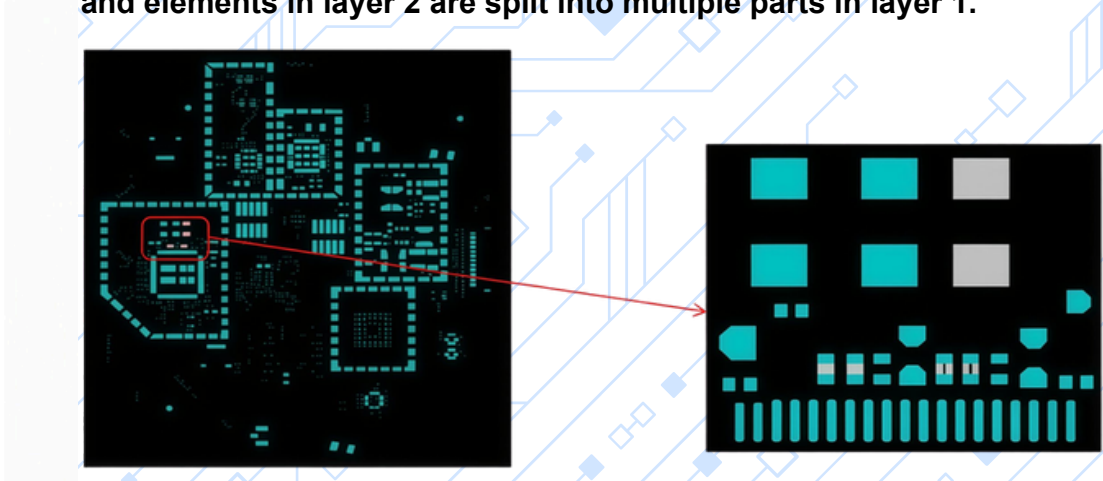

Check the stencil thickness and aperture wall smoothness to verify incoming new stencils.

The backlight passes through the stencil openings, and a high-resolution thickness measurement camera, installed at an angle, identifies and calculates the stencil aperture walls based on light and dark contrast. This allows precise measurement of stencil thickness and the smoothness of aperture walls.

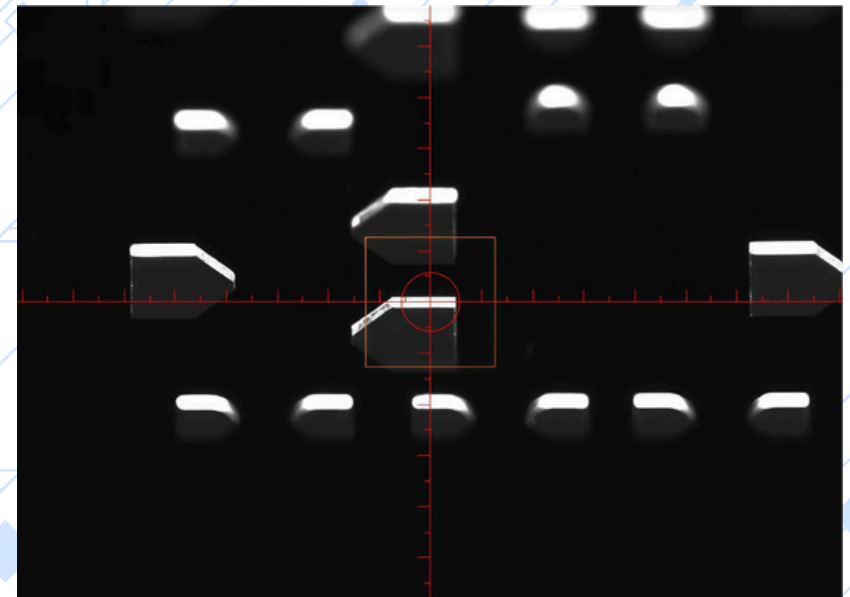
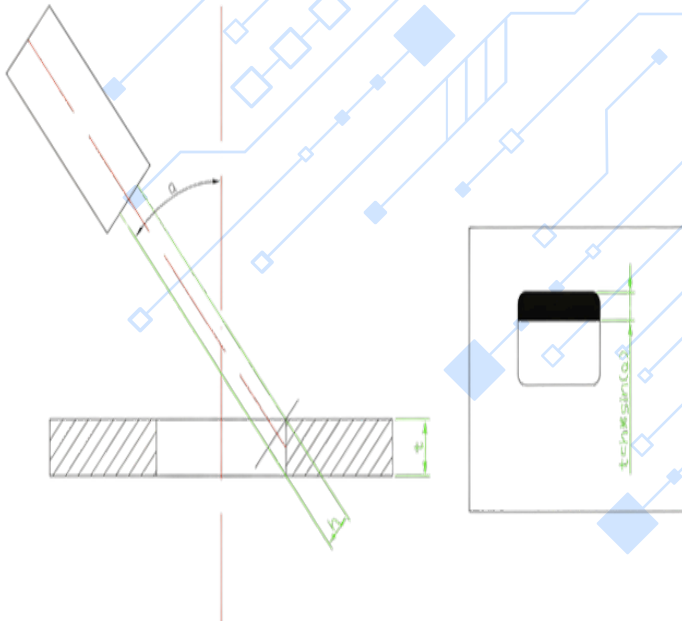

Check whether the squeegee is deformed, raised, recessed, warped, or has uneven ends to prevent potential printing issues.

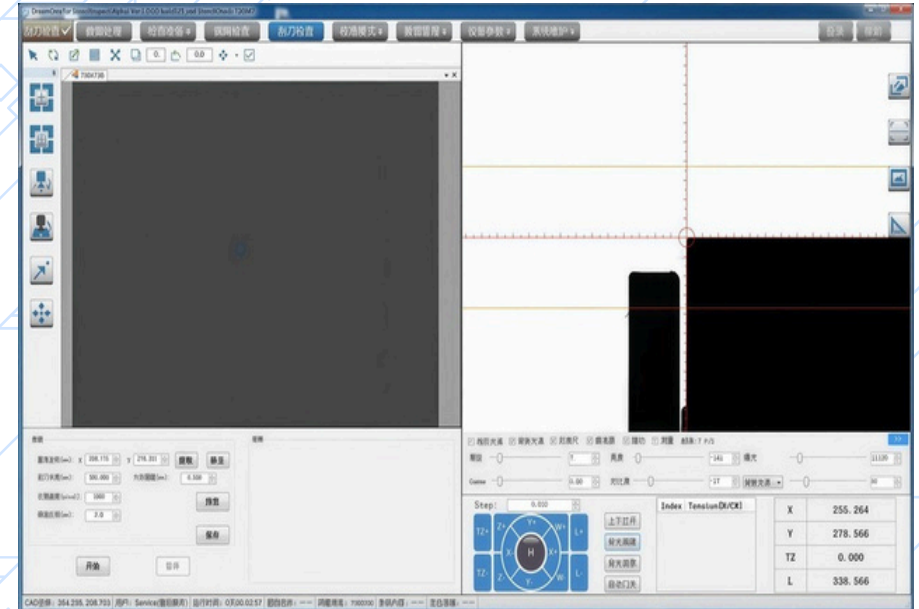
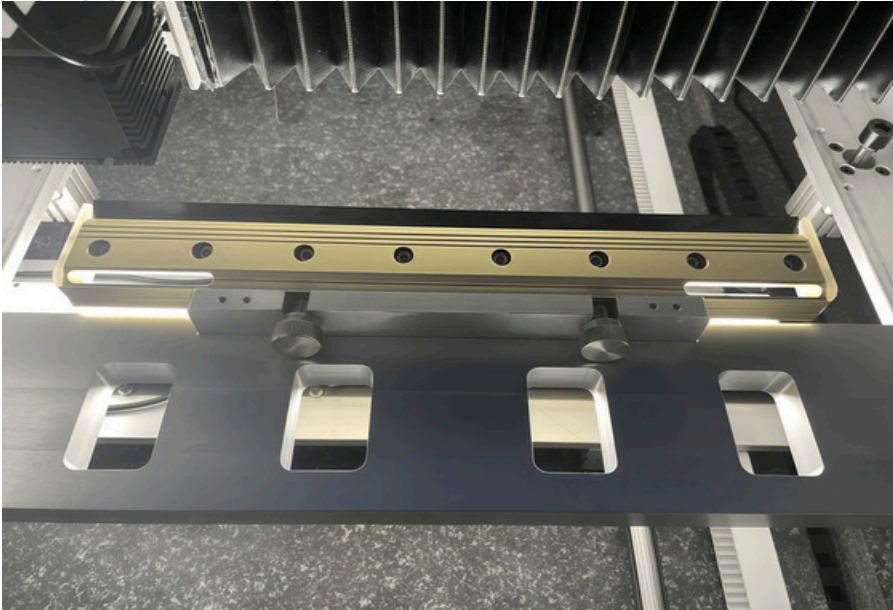

As a stencil serves as a mold for transferring solder paste, the final product may be hundreds or even thousands of times more valuable than the stencil itself. Therefore, continuous inspection and verification of stencil quality is an essential step in SMT production. Dezhong Company, based on the data processing software CircuitCAM7 and the equipment control software DreamCreaTor, has matched the corresponding hardware to ensure precise and reliable operation.

Process improvement enables effective monitoring of stencil condition and maintenance throughout its lifecycle.

1. Resolve incoming material defects and cleaning inspection issues, and improve the cleaning process.
2. Replace manual inspection to enhance product quality.
3. Address printing issues at the source, such as excess solder, insufficient solder, or solder bridging.
4. Support for 01005 and smaller components; high-precision inspection aligns with future development trends.
5. Stencil thickness inspection – verify whether the stencil thickness meets requirements.
6. Squeegee condition inspection – check whether the squeegee is deformed.
7. MENS system – customized industrial software for data collection.
8. Stencil management system – requires clear customer requirements and software development.
9. Stencil cleaning management.
10. MES integration.

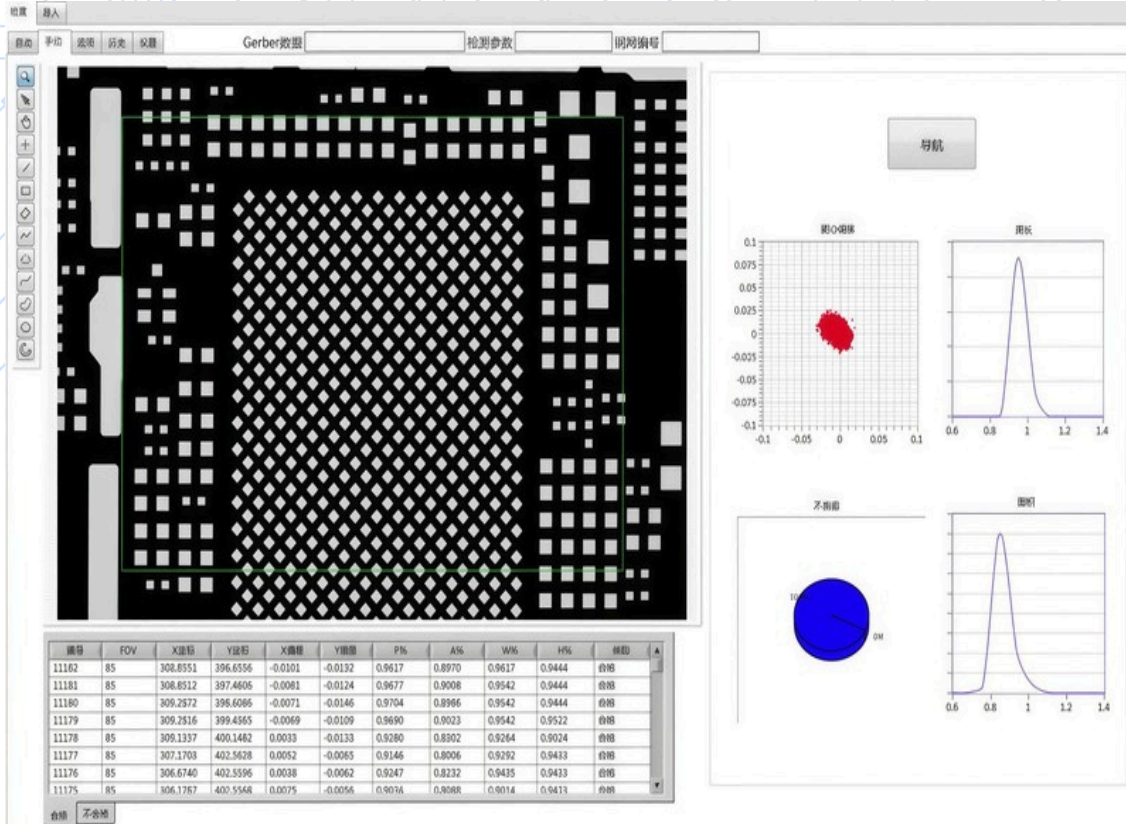

Inspection-related data of the stencil is automatically saved, facilitating analysis, statistics, and traceability.

For the same stencil, comparing inspection data from different time periods allows effective prediction of its condition trends and lifespan.

No issues detected; sample is qualified.

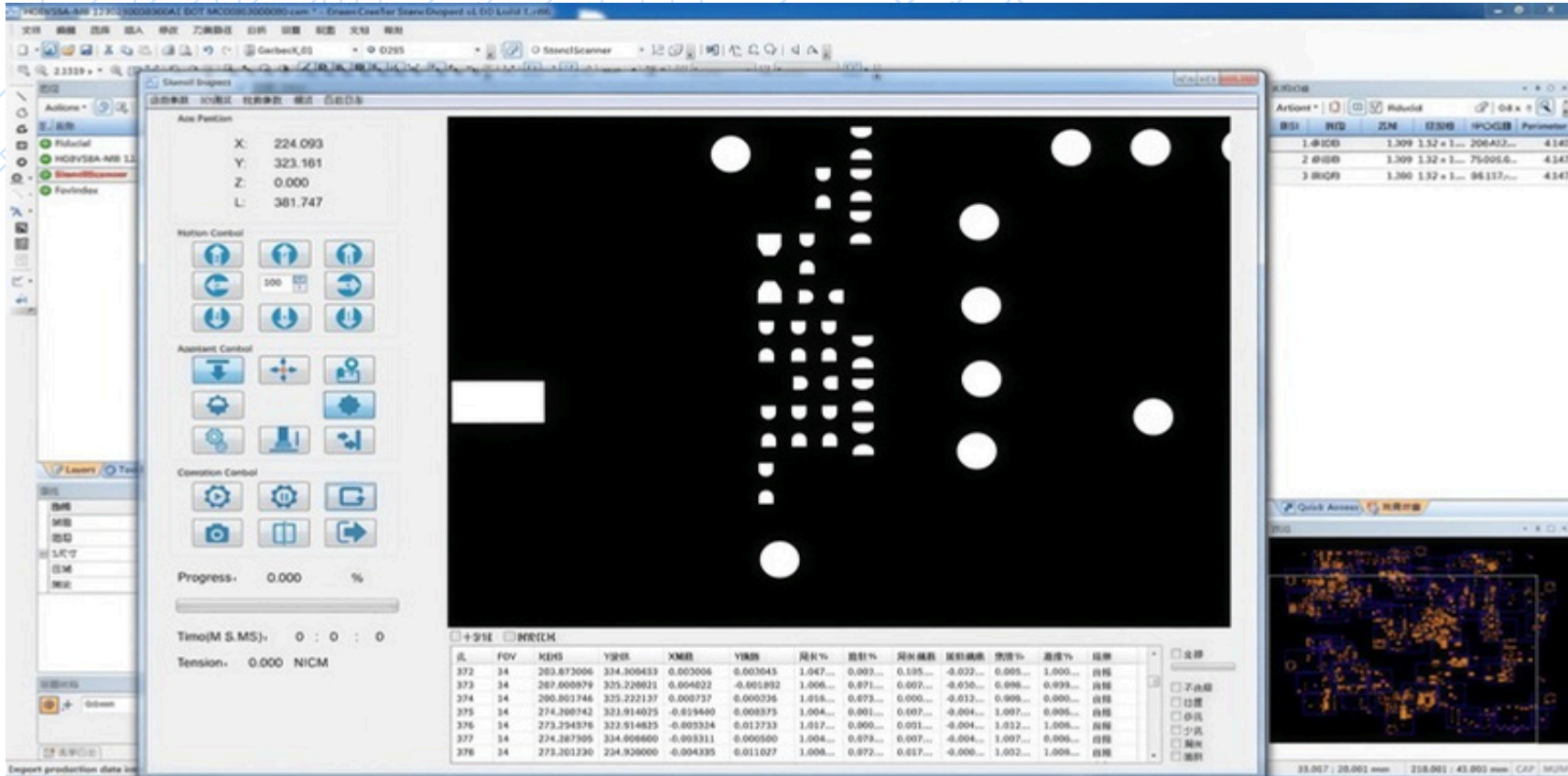

The screenshot displays the Solucinde Stencil Inspection software interface. The main window shows a black stencil with a grid of white circular holes. The interface includes several control panels:

- Axis Position:** X: 224.093, Y: 323.161, Z: 0.000, L: 361.747
- Rotation Control:** Includes buttons for rotation and a speed setting of 100.
- Assistant Control:** Includes buttons for zooming and other navigation functions.
- Camera Control:** Includes buttons for camera settings and zoom.

At the bottom, there is a data table with the following columns: 孔 (Hole), FOV, XMS, YMS, XMR, YMR, 周长% (Perimeter %), 面积% (Area %), 周长公差 (Perimeter Tolerance), 面积公差 (Area Tolerance), 亮度% (Brightness %), 对比度% (Contrast %), and 结果 (Result). The table shows data for several holes, all with a result of '合格' (Qualified).

孔	FOV	XMS	YMS	XMR	YMR	周长%	面积%	周长公差	面积公差	亮度%	对比度%	结果
372	34	263.873006	334.308433	0.003006	0.003045	1.047...	0.003...	0.105...	-0.022...	0.005...	1.000...	合格
373	34	267.000879	325.226031	0.004622	-0.001892	1.006...	0.871...	0.007...	-0.036...	0.998...	0.939...	合格
374	34	266.803746	325.222137	0.000737	0.000236	1.018...	0.873...	0.000...	-0.012...	0.998...	0.000...	合格
375	34	274.200742	323.914075	-0.019400	0.000375	1.004...	0.901...	0.007...	-0.004...	0.997...	0.996...	合格
376	34	273.294376	323.914625	-0.003324	0.013733	1.017...	0.900...	0.001...	-0.004...	1.032...	1.000...	合格
377	34	274.267905	324.908600	-0.003311	0.000500	1.004...	0.879...	0.007...	-0.004...	1.007...	0.996...	合格
378	34	273.261230	224.920000	-0.004335	0.011027	1.008...	0.872...	0.017...	-0.006...	1.002...	1.000...	合格

Issues detected; missing apertures.

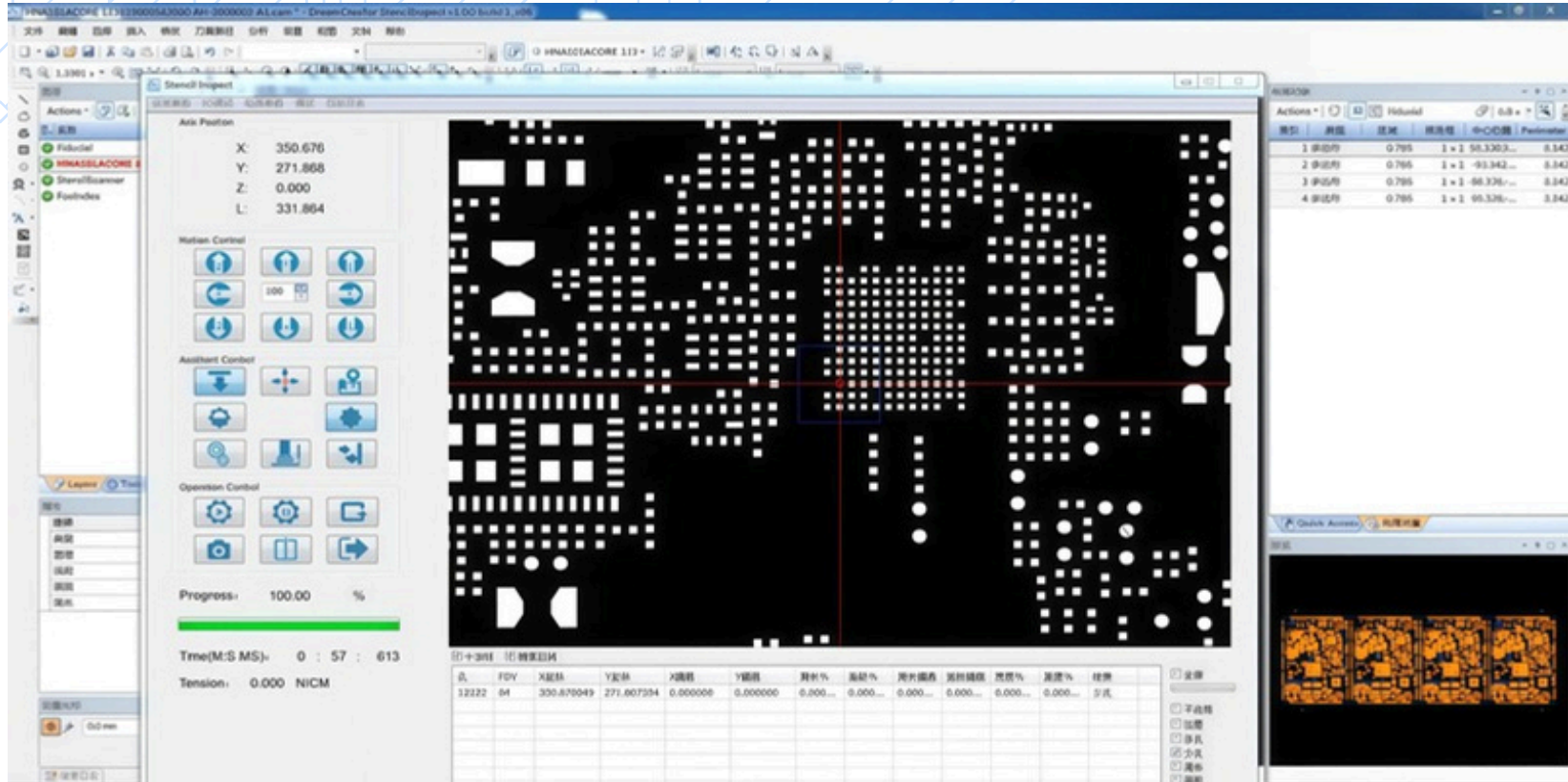

Issues detected; burrs present.

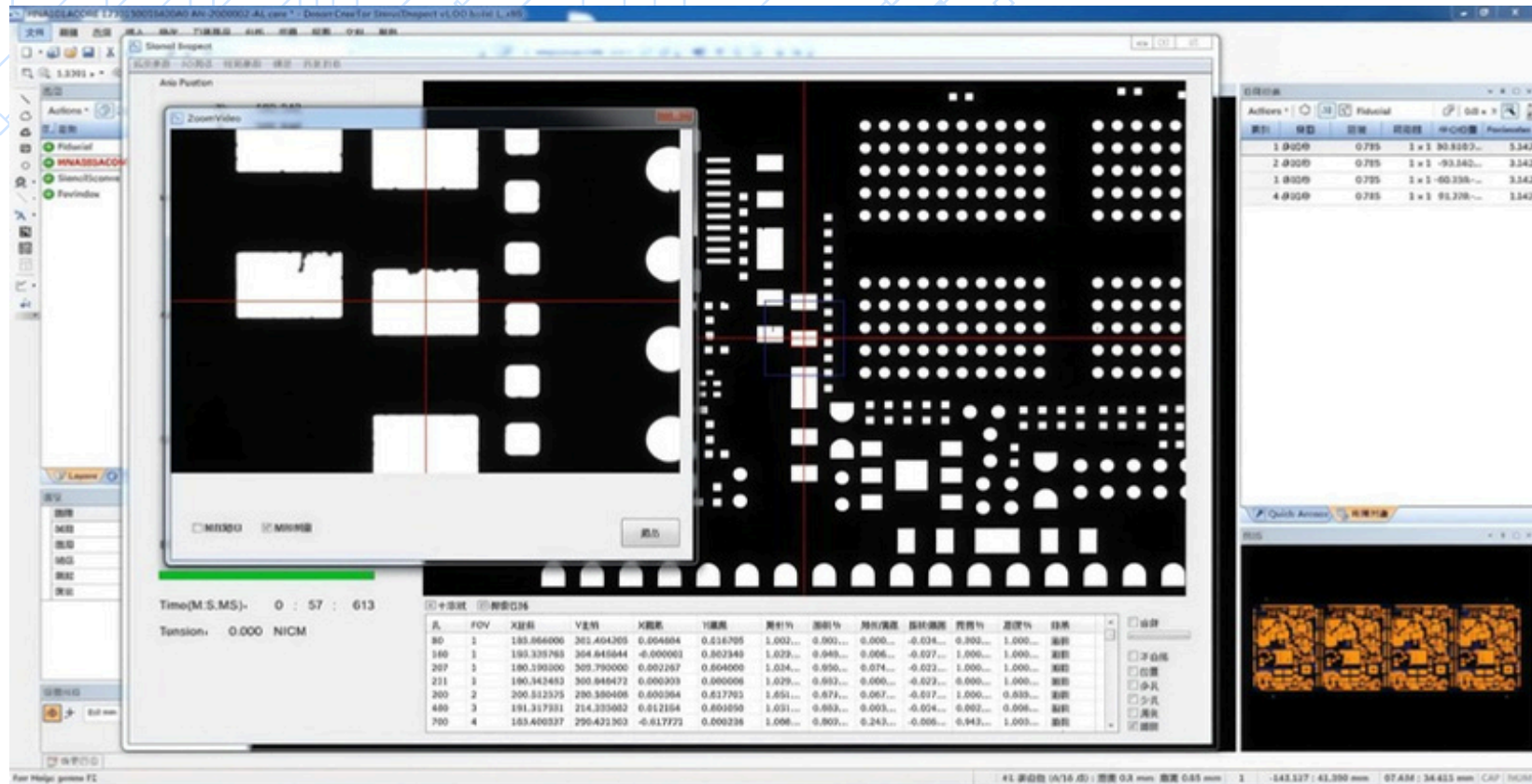

The screenshot displays the Solucinde software interface for stencil inspection. The main window shows a grid of holes with detected burrs highlighted in red. A zoomed-in view of a hole is shown in the top-left corner, with a red crosshair indicating the location of the burr. The interface includes a menu bar, a toolbar, and a data table at the bottom.

孔	FOV	X坐标	Y坐标	X距离	Y距离	面积%	面积%	周长/面积	面积/周长	周长/面积	面积%	面积%
80	1	185.864000	302.404200	0.004604	0.216705	1.002...	0.900...	0.500...	-0.024...	0.303...	1.000...	缺陷
140	1	195.335788	304.648644	-0.000001	0.802340	1.029...	0.949...	0.006...	-0.027...	1.000...	1.000...	缺陷
207	1	180.190100	305.790000	0.002167	0.604000	1.024...	0.950...	0.074...	-0.023...	1.000...	1.000...	缺陷
211	1	180.342452	300.848472	0.000303	0.000000	1.029...	0.982...	0.000...	-0.023...	0.000...	1.000...	缺陷
200	2	200.312325	280.380408	0.000384	0.217702	1.051...	0.871...	0.067...	-0.017...	1.000...	0.833...	缺陷
480	3	191.317381	214.335982	0.612164	0.603890	1.031...	0.883...	0.003...	-0.024...	0.992...	0.006...	缺陷
790	4	183.400327	290.431303	-0.617722	0.000236	1.006...	0.807...	0.243...	-0.006...	0.943...	1.003...	缺陷

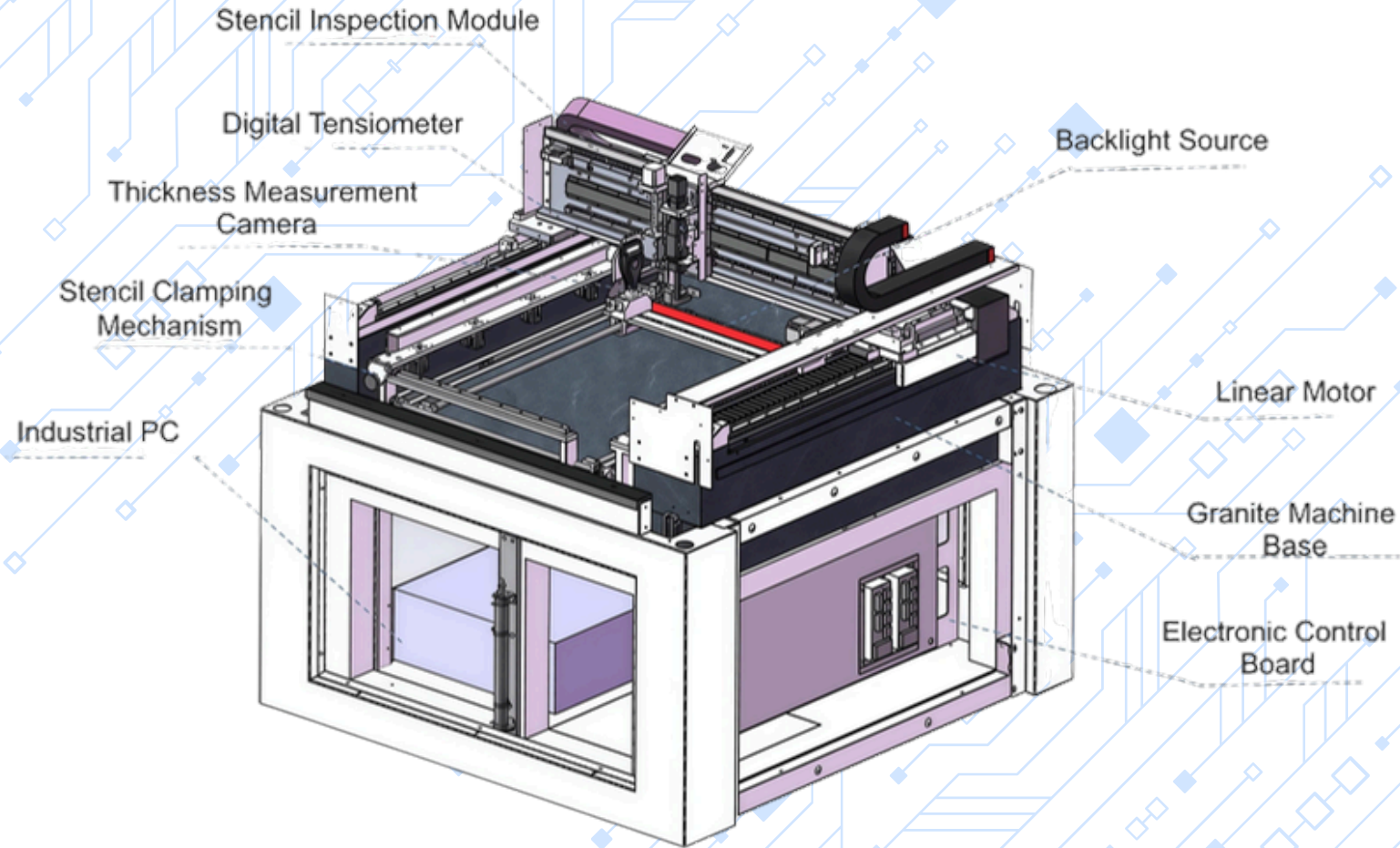

No.	Technical Parameter	D1200 Stencil Inspection Machine
1	Measurement Items	Aperture area, position, offset, size, foreign matter, burrs, clogged apertures, missing apertures, extra apertures, tension
2	Measurement Time	50s (for standard 130mm × 100mm stencil, data: 25,122 apertures)
3	Aperture Area Measurement Accuracy	Gage R&R <5.0% (actual measurement GR&R <1–2%)
4	Aperture Position Measurement Accuracy	±10 μm
5	Transmission Mechanism Accuracy	Repeatability ±4 μm; servo system (resolution: 0.5 μm)
6	Tension Measurement	±0.1 N·cm, tension range 0–50 N.cm
7	Camera	5MP / 10MP / 12MP (default) / 20MP
8	Lens	Dual telecentric lens
9	Illumination	Special white LED backlight (linear light source)
10	Resolution	Default 7.3 μm, customizable
11	FOV	24mm × 16mm (optional)
12	Motor	Linear motor
13	Platform	Granite platform
14	Scanning Range	550mm × 550mm

No.	Technical Parameter	D1200 Stencil Inspection Machine
15	Frame Size	Maximum 736 × 736 mm
16	SPC	Aperture position, area, size; SPC data analysis and summary reports, including tables and charts
17	Gerber File	RS-274, RS-274X
18	Offline Programming	Supports offline programming and preview
19	Power Requirements	220V, 50/60Hz, Power: 1.5 kW
20	Machine Dimensions	1327 × 1266 × 1500 mm (L × W × H), excluding signal tower
21	Air Source	0.4–0.6 MPa
22	Machine Weight	1000 kg
23	Data Traceability	Automatic saving of inspection data
24	Comparison Function	New vs. old stencil data comparison
25	Report Generation	Automatic generation of inspection reports
26	MES Integration	Open communication protocol, capable of real-time data interfacing with market MES systems
27	3D Thickness Measurement Module	Optional
28	Squeegee Inspection Module	Optional
29	Custom MES	Optional

CLEANING MACHINES



**Cleaning****Detection****Management**

- Eliminates the need to manually remove the nozzle from the nozzle station for cleaning and then re-insert it into the nozzle station after cleaning
- There is no need to manually check the status of the nozzle or start production on the machine to find that the nozzle is defective.
- Defective nozzles are classified according to the cause of the failure, and the scrapped nozzles are well documented
- Automatic generation of cleaning job reports to check that the required cleaning cycle is being implemented.
- MES interconnects to manage the inventory of nozzles, query and track the status of each nozzle.

Eliminates 100% of bad nozzles from the machine to ensure quality and efficiency.

Cleaning with Robots

Unload the nozzle exchange station of the placement machine and install it into the cleaning machine

After cleaning, take out the nozzle exchange station from the cleaning machine and install it in the placement machine

Advantages of Automated Cleaning Process:

Almost zero operator time required

Move the nozzle change station from the pick-and-place machine to the NCR to start cleaning the nozzles

Simple process operation makes it easy to implement periodic cleaning management control

Project	Specification Name	Details	
Target: Mounter	FUJJI NXT &AIM series suction nozzle	NXT scries, AIMFX series	
Machine Dimensions	Width x depthx height(mm)	500×1000×1420	
nozzle placement table/Nozzle holder	HO8/12 series, H24 series	Install the nozzle placement table orginally on the machine	
Corresponding nozzle	Special nozzles only for cleaning and 2D inspection	H24,HO8/12 series	
Corresponding nozzle diameter	Large diameter nozzles are only for cleaning and 2D inspection	Standard nozzles of φ0.2~φ5.0	
Nozzle Tray	Trays for cleaning	H08/12 series	Cleaning: 45 PCS/tray Storage box 5 4 PCS/tray
	Trays for storngce Boxes	H24	Cleaning 63 PCS/tray Storage box 71 pcs/tray
The number of installed nozzle placement table	The maximum number of installed nozzle placement table	3 nozzle placement tables (Cannot mix different types)	
Nozzle storage box	Mainmachinelinkage for automatic line change	H08/12 Series, H24 can hold up to 19 nozzle trays With	
Picking Section	Composition	X, Y, Z, Q-axis and nozzle inspection configuration	
	Identification method	NXT uses a fixed camera	
Cleaning Section	Composition	Y Axis	
	cleaning method	Throught high-pressure spray cleaning	
Cleaning fluid	Recirculating System Capacity	Industrial distilled water	6L
Front-end image processing inspection	recognition methods	OFC light source retrofit camera	
Sliding Resistance Inspection	recognition methods	Force sensor/Load Cell	
Inspection Pass/Fail Determination Method	2D Reading	Use fixed camera to judge if image processing is possible	
	nozzle cloggcd	Use two types of flowmeters with different orifice sizes to measure negative pressure flow	
	Front-end dirt and defects	Nozzle Front-end image processing	
	Movement resistance	Use force sensor to measure load	
Air source	Supply air pressure	0.35~0.5MPa	
	consumption Rate	46L/min	
power supply	supply Voltage	220V single phase	
Cycle time	Interlock	Nozzleconfirmationand2D inspection	76 seconds
	Nozzle loading	63 nozzles loaded	137 seconds
	Nozzle clearing	63 nozzles cleaned	124 seconds
	Check ard loading	63 nozzles inspection and return	1098 seconds

Functions:

1. Thoroughly clean the dirt on nozzles which ultrasonic cleaner can not clean.
2. strong clean power for nozzles, even the smallest nozzle hole.
3. very good cleaning effectiveness, extend lifespan of the nozzles.
4. No damage to the coating layer of the nozzle and its reflector panel.
5. only use DI water or distilled water.
6. Autoclean and dry.
7. Easy operation.
8. Right for all kind of mounter nozzles.

Parameters of machine:

Size: (L*W*H)	598mm × 396mm × 365mm
Power (three phase two wire)	2P2W, 220VAC , 50/60Hz, 20A
Power supply	250W
Air source pressure	0.5 - 0.6MPa (Normal operation time)
Weight	Approx. 40 KG
Parameters for electrical control	
Total power	200W
Controlling mode	Touch screen+PLC
Clean time	3~6min
Dry time	1~3min
Air source	Pure compressed air
Jet pressure	≤ 0.4 MPa
Air wastage	Under 280NL/min
Liquid type	Industrial purified water
Liquid consumption	300CC/hour
Liquid storage capacity	800cc
Admission pipe/Drainpipe	φ 8 / φ 6
Specification of nozzle tray	Default 30 nozzles
Noise	35-60 dB

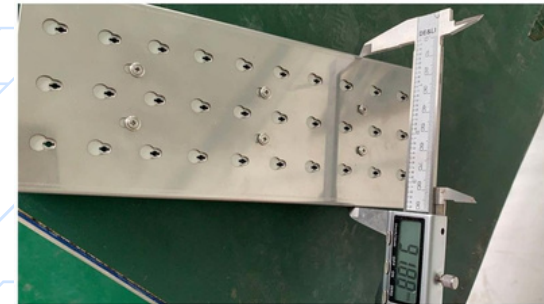

Suction nozzle cleaning machine Cleaning before and after comparison

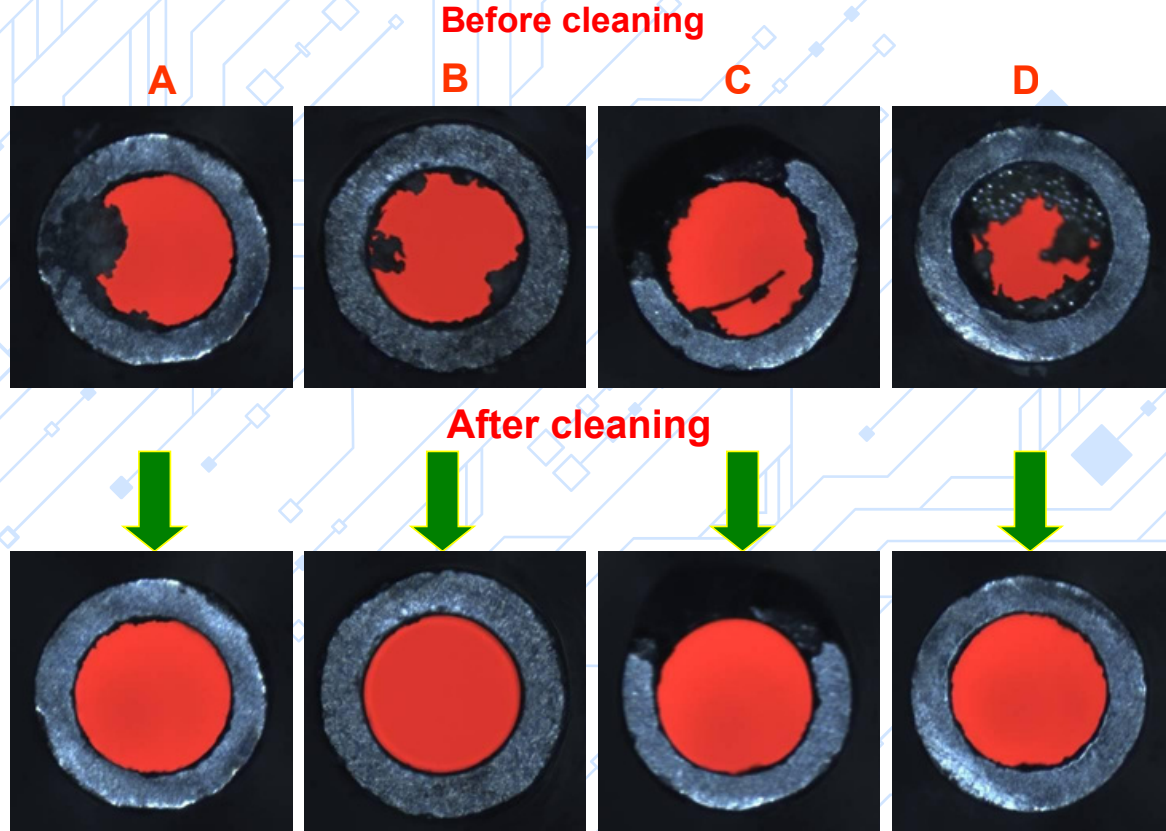

Suction nozzle cleaning machine Cleaning before and after comparison

Before cleaning

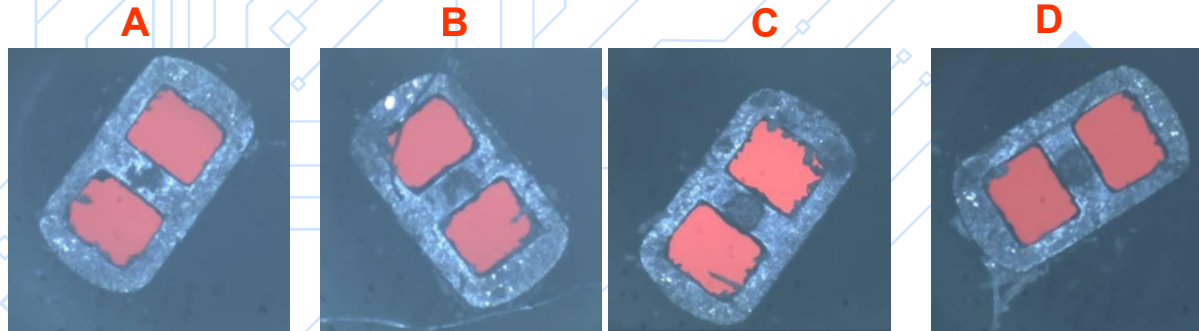

After cleaning

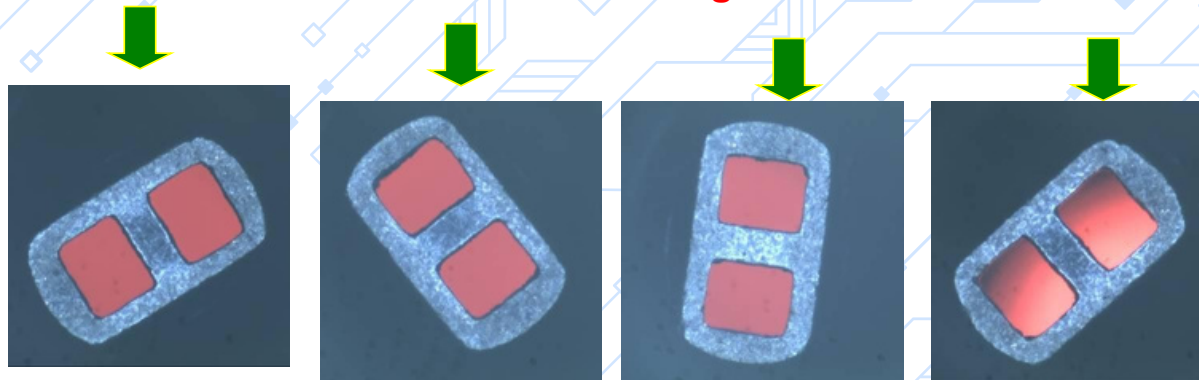

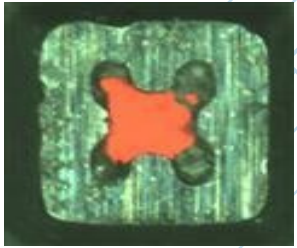
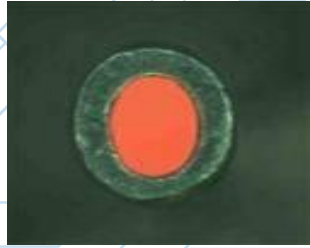
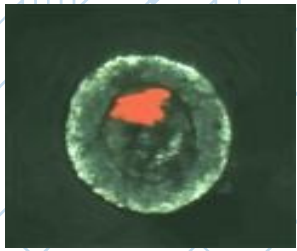

High-efficiency cleaning mode

In the process of SMT, the suction nozzle is quite easily adhered with solder paste or dirt etc. If maintenance has not been done for a long time or the cleaning is not thorough enough while maintaining it, the paste and dirt will be hardened so as to increase the difficulty of cleaning, even it will result in blockage and scraps after long-time accumulation.

YZ-U24
It practically proves that the cleaning machine can effectively deal with inflexible solder paste and thoroughly clean the suction nozzle with complex structure.

Increase SMT quality

- Increase the mounter's adsorption force and mount rate and realizes the improvements of mount quality.

- After using cleaning machine, the discarded material rate of the current customers decreases 20-30%(each company has some difference due to company equipments, feeders,workers, maintenace status of suction nozzles.

reduce labor cost

- reduce the clibration times of PCBs .
- It can use much shorter time to clean suction nozzle compared to the previous one.

- Let's take 96pcs suction nozzles as example: manual cleaning needs 1 hour, suction nozzle machine just needs 20 minutes. After using the suction nozzle machine, it can reduce 1-2 workers, which can save a cost of 36-80 thousand.

reduce parts cost

- Reduce the falling-offchips
- Full auto cleaning,which guarantees the cleaning degree and reduce the scraps of suction nozzle.

- The discarded materials or bumping scraps due to the abnormality of suction nozzle, if calculated by 1% as the scraps rate, the cost for purchasing suction nozzles within one year is also quite considerable.

increase productivity

- Can shorten the maintenace time of production line
- Can reduce the abnormal standby time due to suction nozzle.
- Can make more products

- Single line's online maintenace takes 1 hour as example, after using suction nozzle cleaning machine, it can be shortened to 30 minutes. If it is maintained once a week or two weeks, each single line can save 12-24 hours of maintenace each year used for production.

Solve problems**Create more profits for customers**

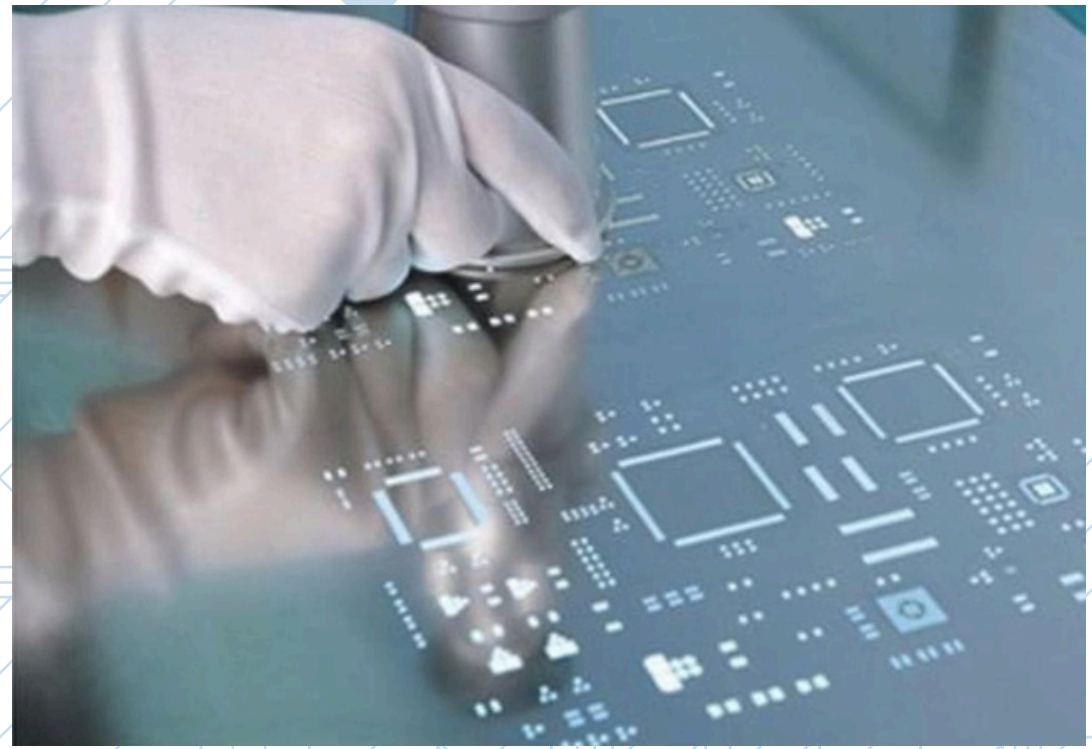

Problem:

- Still manual to clean the stencil?
- Does it safe?
And does it really clean after cleaned by manual?
- If not clean enough, it will lead to the printing problem, have you ever met it?

Solve:

- All pneumatic, no safe hidden trouble, avoid fire
- Easy to operate, the price is cheap
Clean the stencil absolutely

Y-750 Stencil Cleaner Machine

Great cleaning effect, for BGA hole with Hole diameter 0.1 mm, 0.3 spacing of QFP or 0201 chip component hole, all those can be cleaned completely.

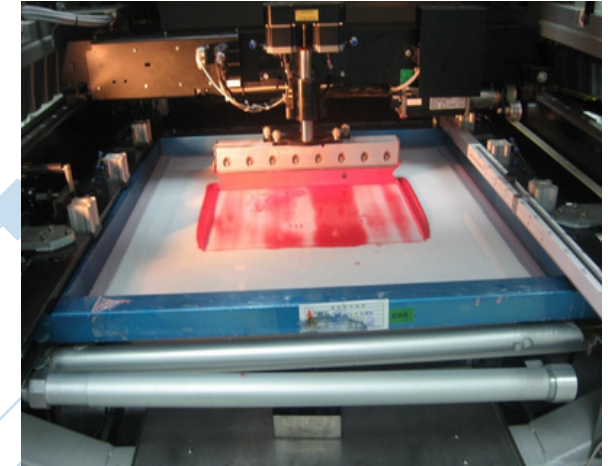

stencil for red gum

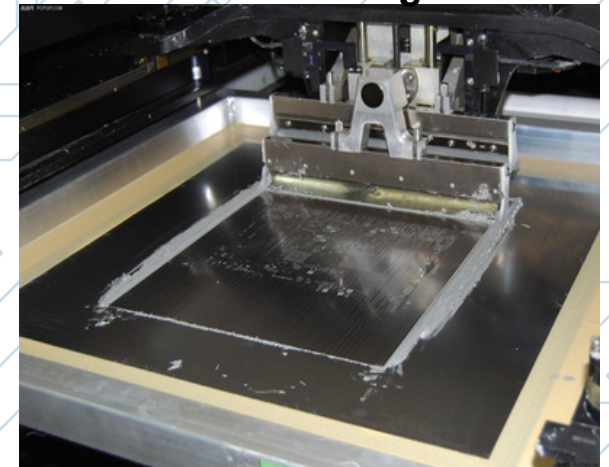

stencil for tin cream

Features:

- 1, No need electronic power, no fire and detonate caused.
- 2, Simple operation, only Start, Stop and Reset, that is all.
- 3, Protecting Environmental, water recycle. Also can use IPA, alcohol or hydrocarbons are allowed, we suggest to use environmentally friendly cleaning agent
- 4, Lower consumption: 2 filters (cost \$40.00) can clean more 200 cycles.
- 5, The design of nozzle is low pressure and high flow, for drying methods, is normal temperature convection, without any damage for the stencil.
- 6, safety and stability, strong ability to clean, solvent- saving, small space occupied, full service



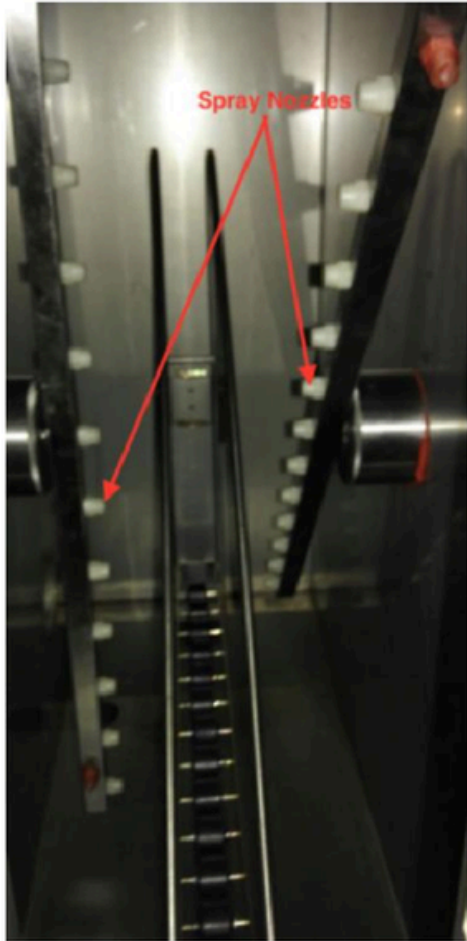

Cleaning Flow Chart

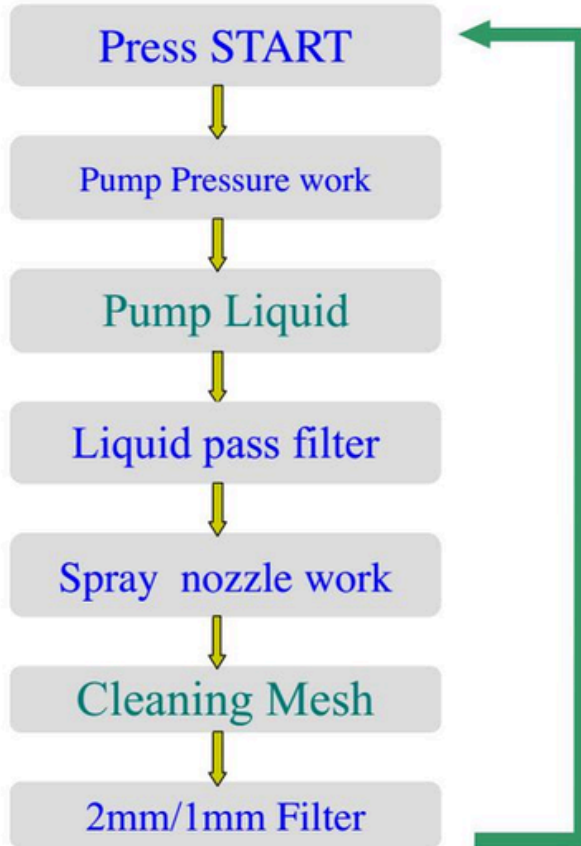

before and after cleaning

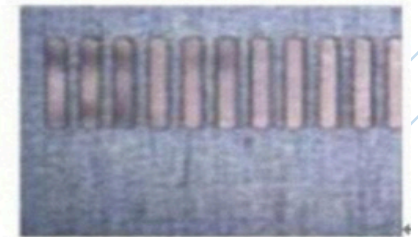
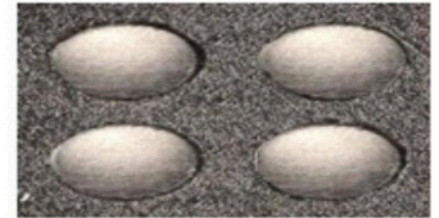
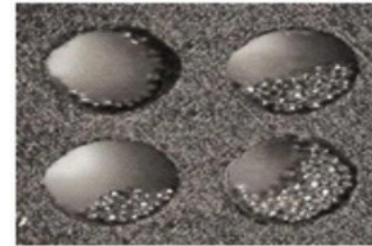

Before cleaning

After cleaning



Automatic, drainage system,
more conducive to the
production of flexible
management

Replaceable modularized controller and the quick insert
design, maintenance, maintenance easy and convenient.



Add cleaning fluid (IPA, alcohol, general hydrocarbons can be, it is
recommended to use kyzen water-based cleaning agent,
environmental protection, safety). Best liquid capacity : 35L

Application stencil,glue screen ,copper screen

Application stencil size :750(L)x750(W)X40mm(H)

Clean liquid capacity :Max 50L ,Min 20 L

Cleaning fluid volume :40L

Cleaning method Rotary double

side pressure injection and high pressure air praying

:cleaning and drying

Clean time :2~4 min(stencil

and copper net)

Rinse time :2~4 min(stencil and

copper net)

Dry time: 2~5 min

External air supply:

0.4Mpa~0.6Mpa

Air consumption :400~600L/Min*2

Air outlet size :Φ125*25mm

Weight: 320Kg

Dimension: 800mm (L) × 950mm (W) × 1630mm (H)

Tin filter method Three class filter: (10μm, 5μm,

1μm)

Detergent: Kyzen Lonox L5611. Water-based

cleaning solution and solvent cleaning solution

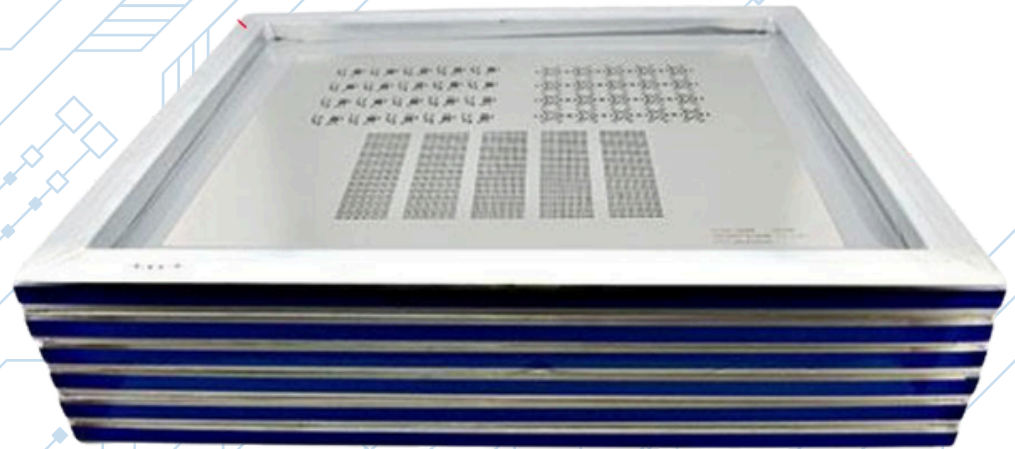

Electric Stencil cleaning machine

Model: E-750



E-750 stencil cleaning machine is mainly used to wash solder paste stencil, red glue stencil, Red glue copper stencil, solder paste mis-printed PCB, squeegees,PCBA.

Aqueous liquid wash, DI water rinse, hot air blow dry process. Our special designed 4 fixed cleaning spray rods, 4fixed air knives and stencil move back and forth design makes the machine stable, reliable and super cleaning performance.

Main modular

1. Wash: water base liquid wash, wash time can be adjusted.
2. Rinse: DI water rinse,rinse time can be adjusted.
3. Dry: compressed air blow dry, dry time can be adjusted.

2. Basic wash flow rate

Put in stencil → Liquid wash → DI water rinse → Hot air blow dry → take out stencil

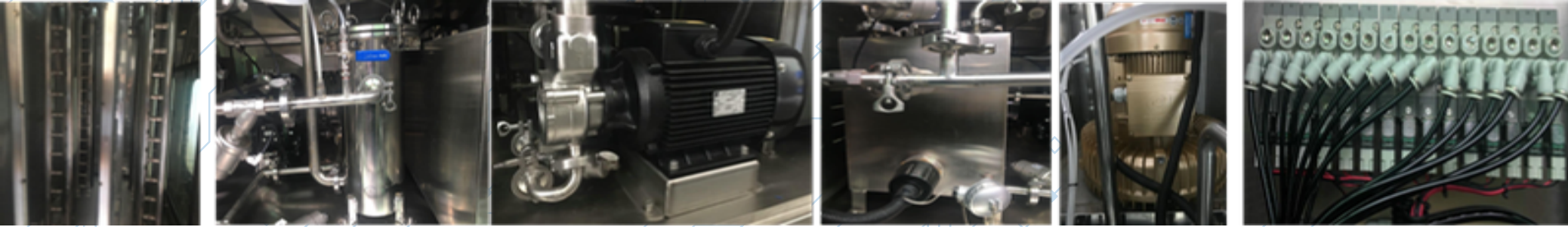

wash cabinet

filter barrel

electric pump

liquid tank

air blower

solenoid valve

Machine features

1. SUS 304 structure, acid and alkali corrosion resistance, 15 years lifespan.
2. Mainly used to clean SMT solder paste stencil, red glue stencil/cooper stencil, misprint PCB,PCBA.
3. 4 spray rods and 4 air knives fixed and stencil moves clean mechanism, more stable.
4. The real-time clean liquid and rinse DI water filtering system.
5. All process is visible through a large right side observe window.
6. The remaining liquid in the pump and pipes are blown off by compressed air and flow back to cleaning tank. This function saves liquid up to 50%.
7. English color touch Panel operational interface, PLC procedure control, clean time, cleaning liquid temperature, rinse time and rinse water temperature, hot air dry time and temperature can be set and monitored as required.
8. Wash liquid and rinse water can be added and discharged automatically.
9. Easy operation.

S/N	Item	spec	remarks
1	stencil size	L737*W737*H40(mm)	max
2	liquid/water tank	60L/60L	
3	wash time	3~5min	solder paste stencil
4	rinse time	1~2min,	solder paste stencil
5	dry time	3~6min	solder paste stencil
6	Wash/rinse pressure	4~5kg/cm2	
7	wash liquid	water based liquid	
8	rinse water	DI water	
9	dry method	Hot air blow dry	
10	liquid temp	0~60°C	
11	hot air dry temp	0~90°C	
12	liquid heater	9KW	
13	water heater	9KW	
14	hot air heater	6KW	
15	liquid/water filter	1um/1um	
16	Power/air supply	AC380V,50/60HZ,28KW/0.5~0.7Mpa	
17	weight	730KG	
18	machine size	1700mm(L) × 1200mm(W) × 2000mm(H)	

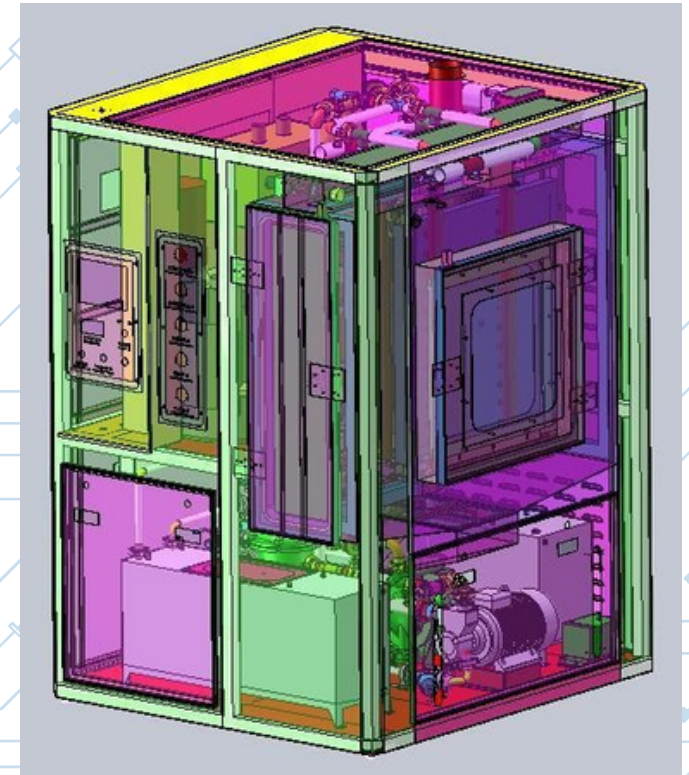

Flow chart

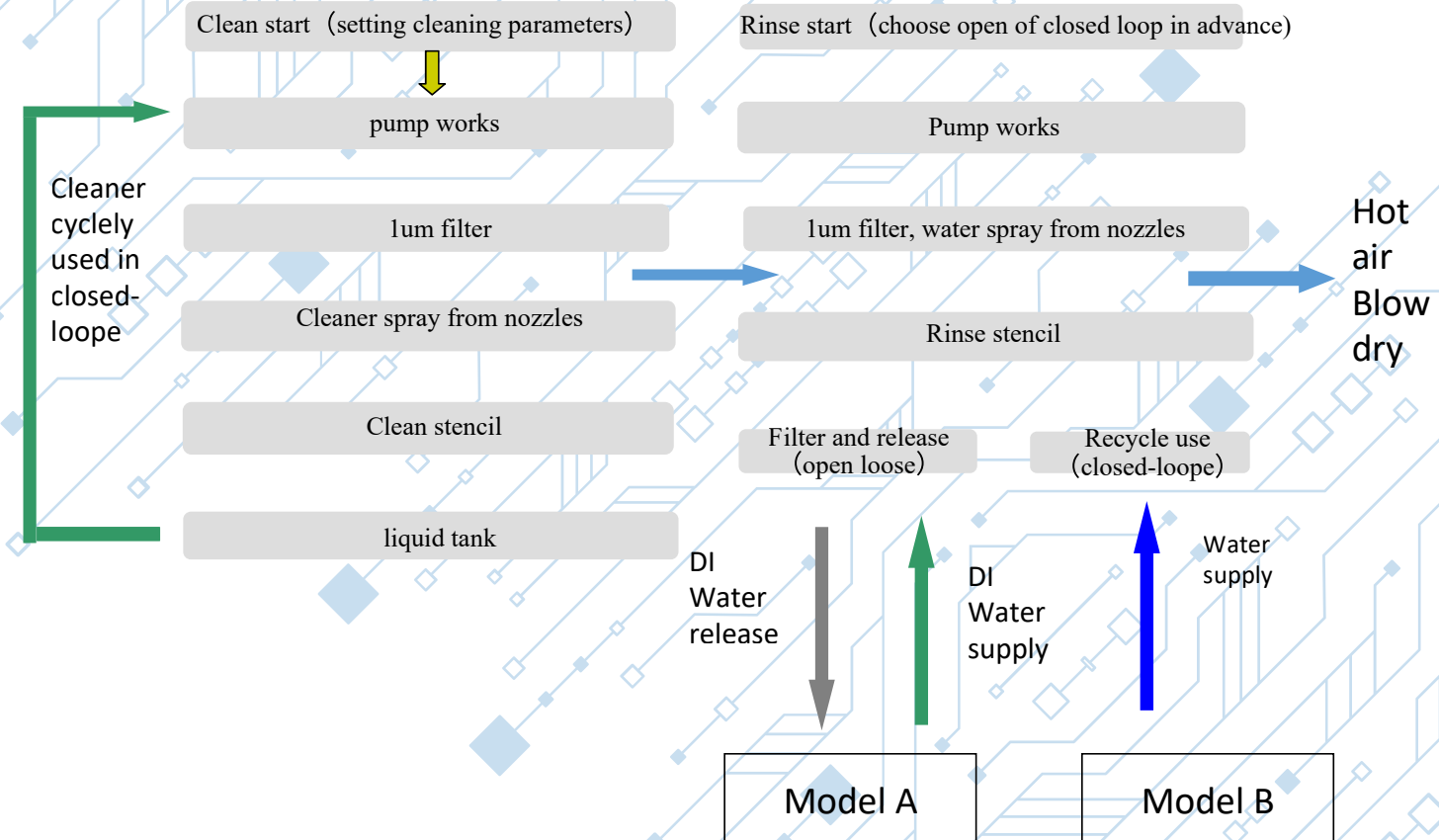

Wash comparison 1

stencilsolderpastewashbefore and after

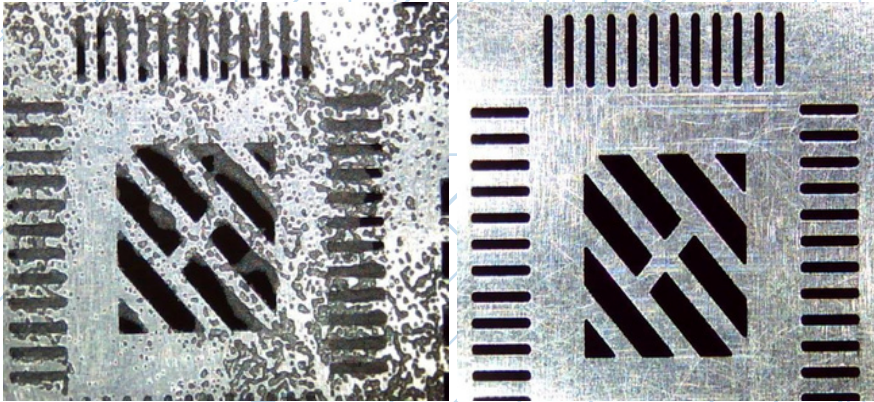

wash comparison 2

Copperstencilredgulewash before and after

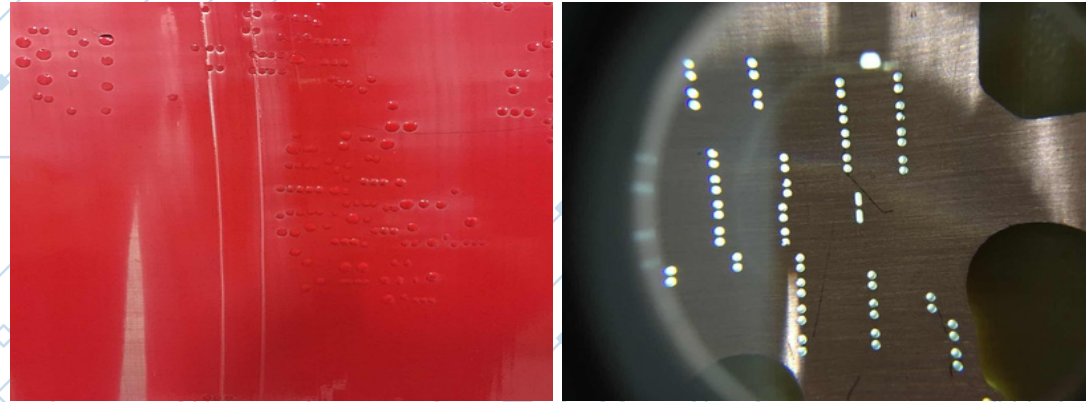

Wash comparison 3

Resinstencilredgulewashbefore and after



1. Main Modular

The device has an integrated structure and can automatically conduct wash, rinse, and dry processes in one chamber. 1. Wash: chemical liquid ultrasonic and spray wash, wash time and temperature can be set. 2. Rinse: DI water spray rinse, rinse time and temperature can be set. 3. Dry: hot air dry, dry time and temperature can be set.

2. Flow chart

Put in squeegees → liquid wash → liquid take back → DI water rinse → DI water take back → Hot air blow dry → take out squeegees





wash room and hexagon rotation device

1. Ultrasonic+Spray wash, very good wash result, especially for solder paste in gaps and corners of squeegees.
2. Hexagon rotation squeegee holdign rack, wash 6 pcs of squeegees one time.
3. Squeegees are easy and convenient to laod and unlaod.

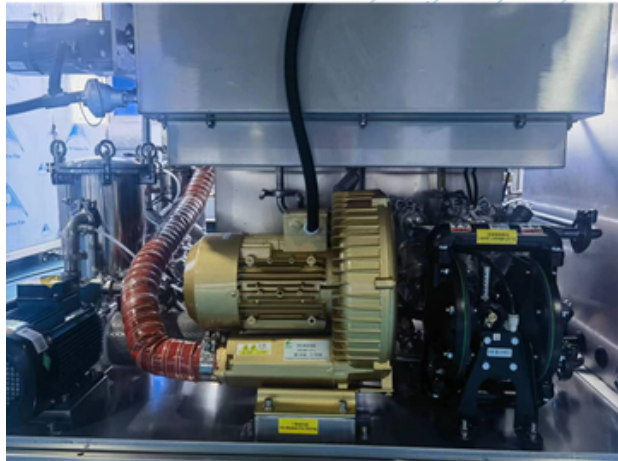

air blower and air pump

2.2KW high pressure air blower with 9KW heater, greatly improve squeegees dry efficient. Air pump use to add and drain liquid or water automatically.

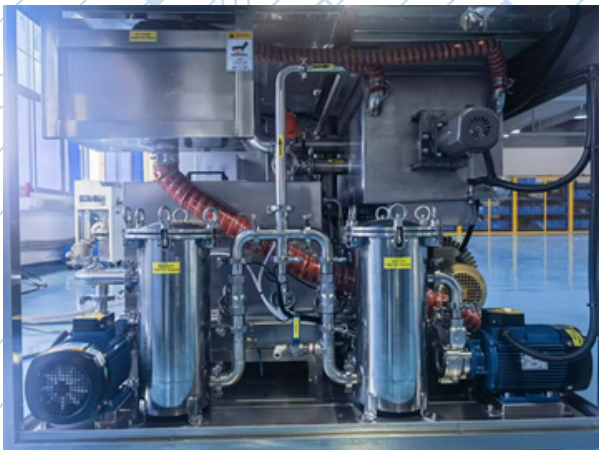

wash electric pump and rinse electric pump.

Wash filter and rinse filter, wash liquid and rinse water recycledly used.

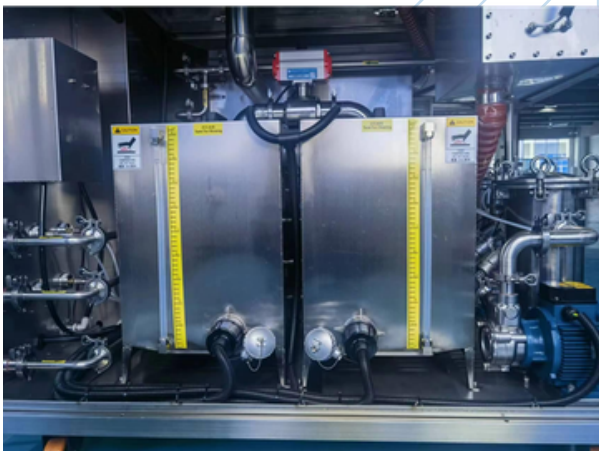

Both wash liquid tank and rinse water tank have liquid level switches, heaters and temperature control sensors, protect pumps, heaters and make wash and rinse easier and more efficient. SUS304 stainless steel pipes, angle valves. Never use plastic pipe, no need to worry about any leak of the system.

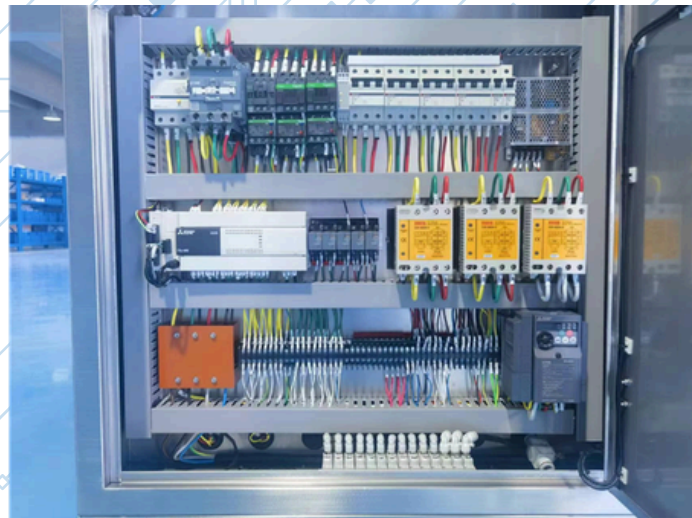

electric control unit

Famous electric parts, like Mitsubishi PLC, HDMI, Inventor, Modular, Air breaker, Schneider AC contactors, relay, CKD solenoid valve, Omron sensor, Switch power, Palite light tower, IDEC keys...



before and after wash

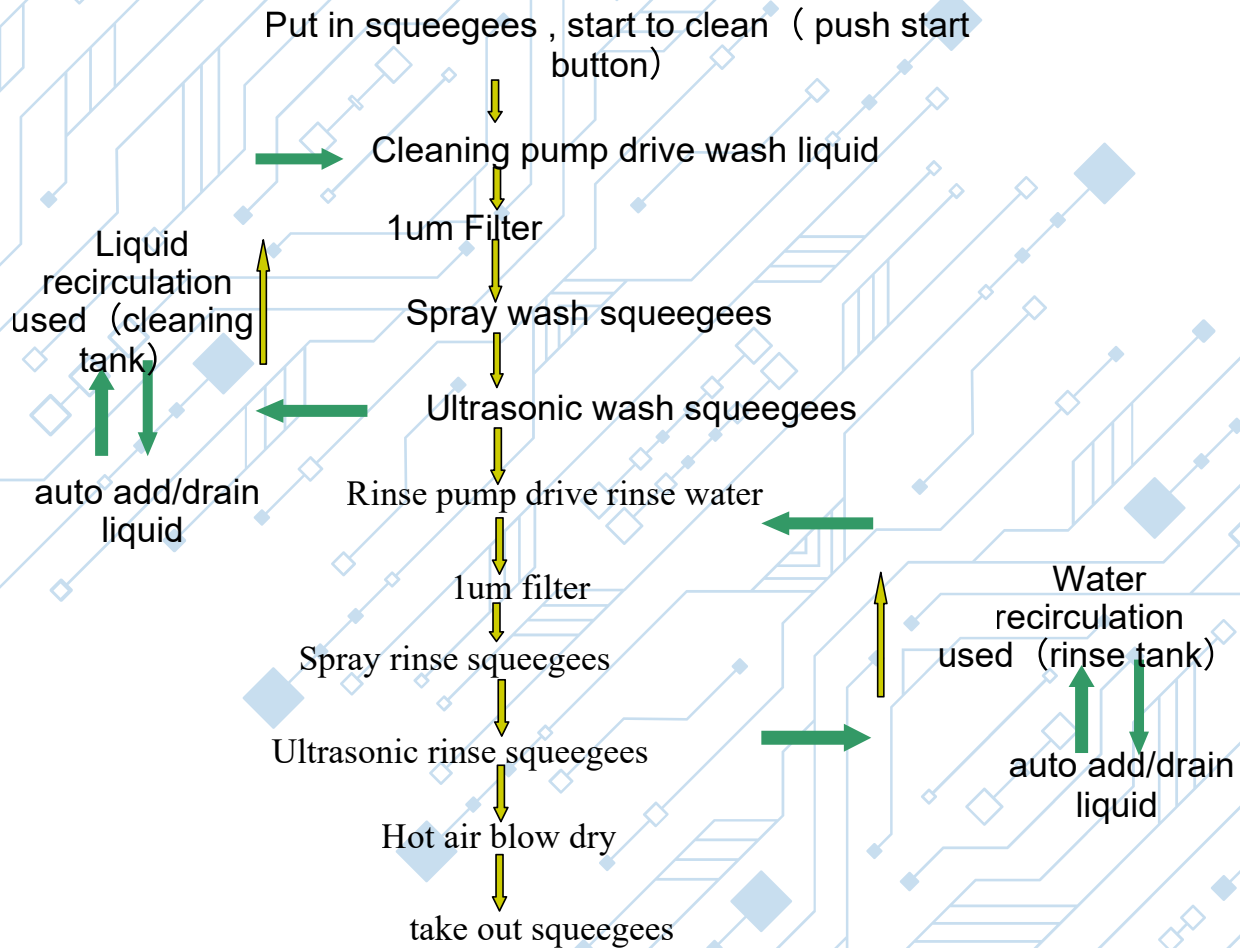

1. All SUS304 stainless steel frame, acid and alkalic corrosion proof, 15 years life span.
2. For all kinds auto printer squeegees on the market.
3. Ultrasonic+spray wash method, thoroughly wash.
4. 360 ° Rotation squeegee system, each side of squeegees can be washed.
5. 6pcs of 20inches and 12 pcs of 10inches squeegees can be washed in one time.
6. Easy operation, wash, rinse and dry process are complete accoring to setting procedures.
7. Visiable window, all process can be watched.
8. Squeegees load and unlaod very convinent.
9. Touch panle, PLC control, Liquid temp, wash time, rinse time, dry time, dry temperature... can be setting according to your requirement.
10. Air pump, auto liquid and water add and drain function.
11. Famous electric devices, ensure machine stable performance and high quality.
12. Wash system+Rinse system, real time filter system.

S/N	NAME	SPEC	Remarks
1	squeegee size	L 600mm	as max
2	squeegee quantity	6 pcs	
3	liquid/water tank capacity	75L/75L	
4	wash time	5~10min	
5	rinse time	1~2min	
6	Dry time	5~15min	
7	wash liquid	water -based liquid	
8	rinse liquid	DI water or tap water	
9	Dry method	high pressure hot air blow dry	
10	Liquid temp	RT~60°C	
11	Dry temp	RT~90°C	
12	Filter	100um+1um	
13	Ultrasonic Power	1.2kw	
14	Clean/rinse pump	1.1kw/1.1kw	
15	Total power	28kw	
16	Power/Air supply	AC380V,50/60HZ,63A /0.5~0.7Mpa	
17	Machine size	L1400xW1300xH1300 (mm)	
18	Machine weight	500KG	



Pallet Fixture cleaning machine

Model: YM-5200

YM-5200 pallet cleaning machine is mainly used to wash soldering wave oven pallet, Reflow oven jig flux. Aqueous liquid wash, tape water rinse, hot air blow dry process. Round basket turns 360°, wash liquid and rinse water spray from upper, lower and front manifolds.

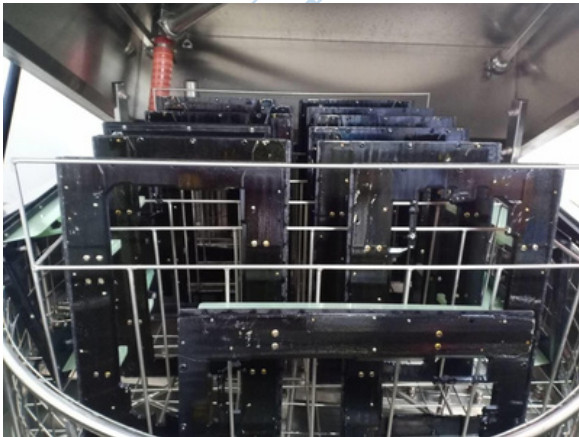

solder wave oven pallets

Main modular

1. Wash: water base liquid wash, wash time can be adjusted.
2. Rinse: DI water rinse, rinse time can be adjusted.
3. Dry: Hot air blow dry, dry time can be adjusted.

2. Basic wash flow chart

Put in pallets → Liquid wash → tape water rinse → Hot air blow dry → take out pallets

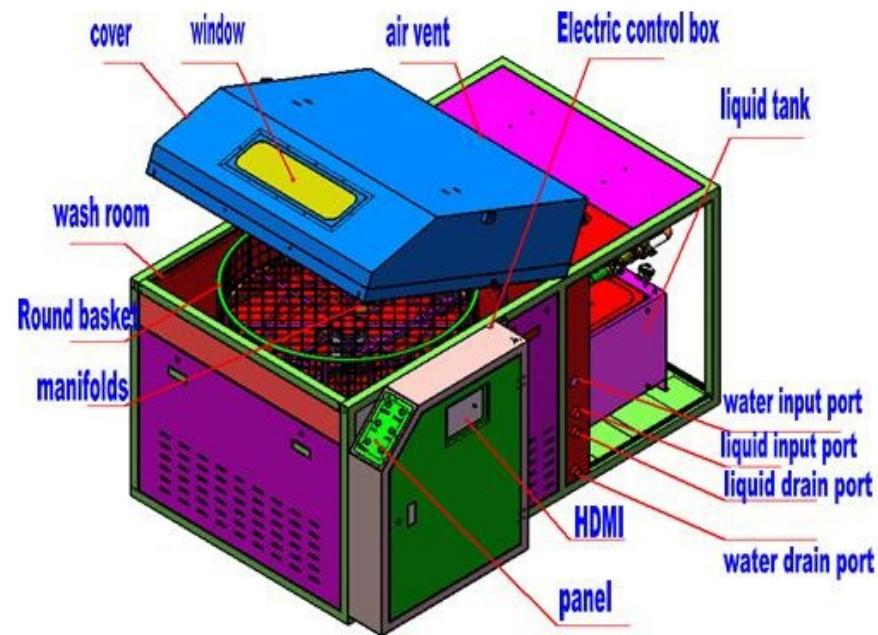



Round basket

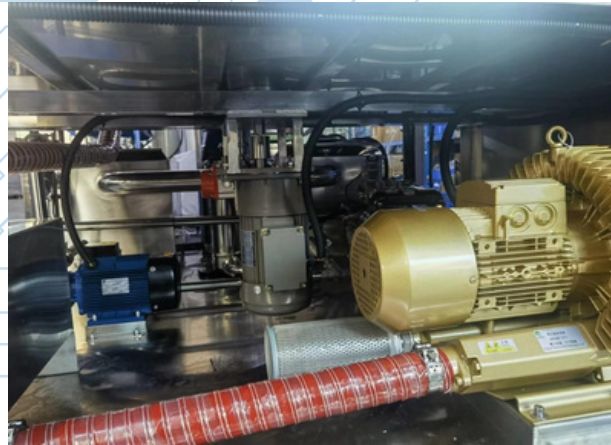

Air blower



Stainless steel pipes



liquid/water tank

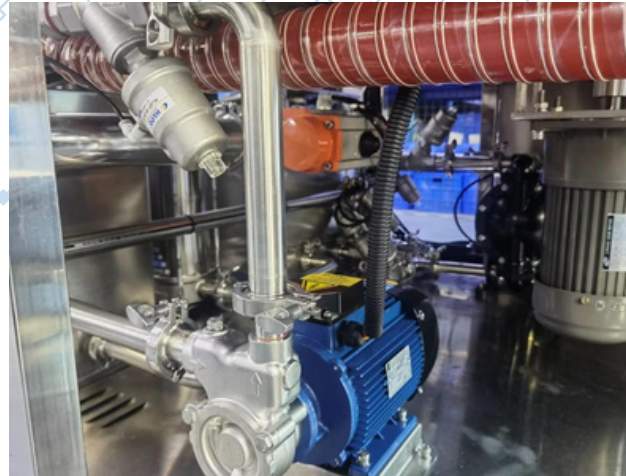

electric pumps

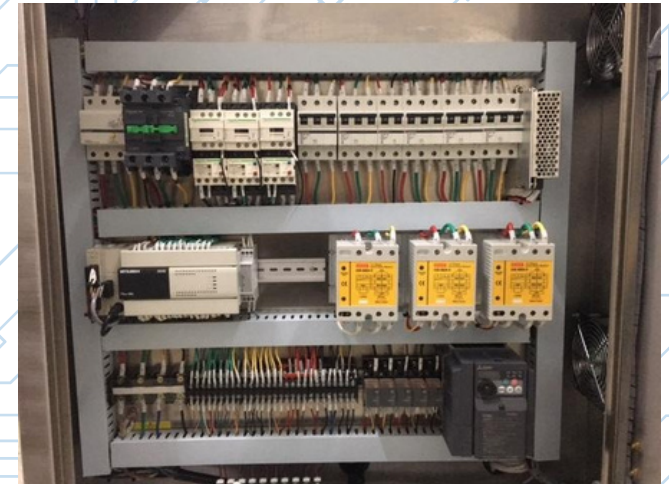

EI

Item	Spec
Cleaning basket diameter	Φ1000mm, clean height 450mm or 550mm option option :Φ1300mm, clean height 450mm or 550mm option option :Φ1500mm, clean height 450mm or 550mm option
Spray unit	Upper/lower/front side,720°, all-around spray
3-level filter system	2mm /100um/20um filters
Clean tank capacity	80L
Rinse tank capacity	80L
Clean spray pressure	5~6 kg/cm ²
Clean time	5~15 Min
Rinse time	1~3 Min 10~20Min
Dry time	Room temp~80°C
Clean liquid heat temp	Room temp~80°C
Rinse water heat temp	Room temp~90°C
Hot air heat temp	2.2KW/1.1kw
Clean/Rinse pump power	9KW
Liquid/Water heater power	9KW
Hot air heat power	4.0KW
Air blower power	0.5~0.7Mpa
Air supply	3 P,AC 380V,50/60HZ,33KW
Power supply	L1400 x W2000 x H 1450 (mm) 1000mm, clean
Machine size	height 450mm
Machine weight	600KG

1. Total SUS 304 structure, resist Acid and Alkali corrosion, firm and attractive.
2. 1 meter diameter big cleaning round basket, can clean 20~40 pcs fixtures at one time.
3. Clean liquid spray from 3 spray rods on upper/lower and front side, cleaning basket rotates during cleaning.
4. Clean liquid pressure up to 6kg/cm², make it thoroughly clean of whole fixture.
5. PLC program control, Touch-panel operation, cleaning parameters can be set and change conveniently.
6. Easy One-button operation, high pressure clean+ rinse+ hot air dry, all process complete in a cycle automatically.
7. Clean liquid and water heat and temperature keeping function.
8. Closed-loop clean and rinse, clean detergent and rinse water are cycling filtered and reused in the machine.
9. Standard equipped solution and water auto fill in and discharge function.
10. Pallets are clean and dry after cleaning, standby and ready for use at any time.

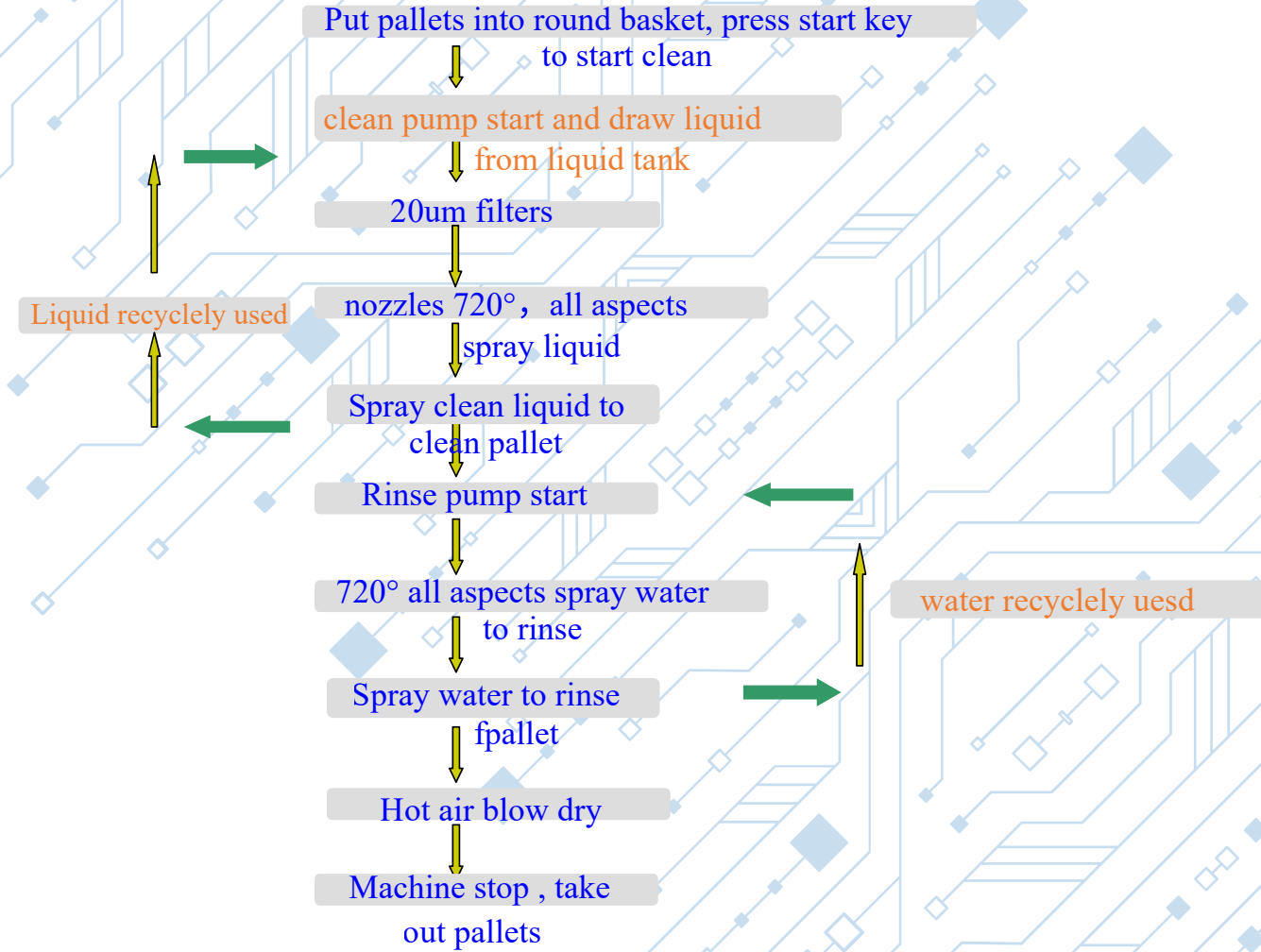

before and after wash

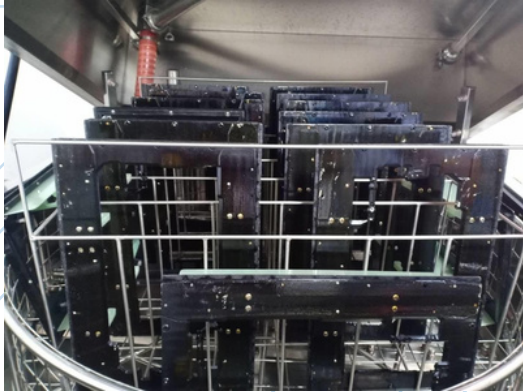

before and after wash



before and after wash



PCBA Batch Type Cleaning Machine

Model: YPA-580



YPA-580 PCBA Offline Cleaning Machine is an integrated high-end cleaning machine that is energy-saving, eco-friendly, and designed for batch cleaning. It can automatically complete the cleaning, rinsing, and drying functions. This machine is mainly used for cleaning multi-variety and small and medium batch PCBA boards of high-end products in industries such as military, aerospace, communications, intelligent instruments, and automotive electronics. It can effectively clean the organic and inorganic pollutants such as the rosin flux, water-soluble flux, and no-clean flux/solder paste residue on the surface of SMT/THT PCBA after soldering.

1. Main Modular

The device has an integrated structure and can automatically complete the cleaning, rinsing, and drying processes in one chamber.

1. Cleaning: chemical liquid cleaning, cleaning time, and temperature can be set.
2. Rinsing: multiple rinses with DI water, rinsing time and number of rinses can be set.
3. Drying: hot air drying, drying time and stability can be set.

2. Flow chart

Put in PCBA → liquid wash → liquid take back → DI water rinse 1 → DI water rinse 2 → DI water rinse → Hot air blow dry → take out PCBA

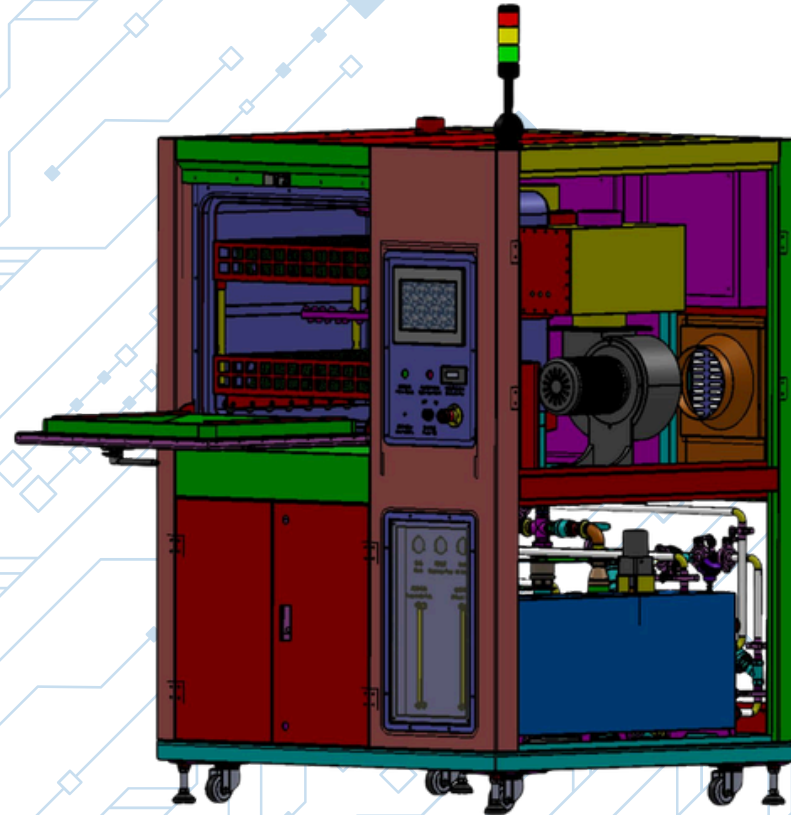



big wash cabinet



wash basket



2 layers seal and observe window

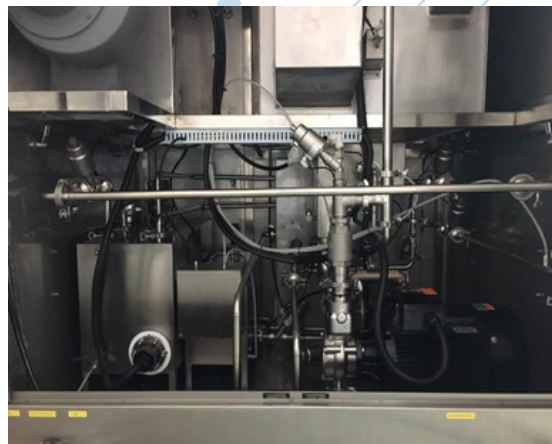

Inner pipes



wash&rinse filters



Electric control box

S/N	Item	Spec
1	wash basket	L610*W560*H100(mm),
2	liquid tank capacity	2 layers 60L
3	concertrate liquid tank capacity	30L
4	temporary tank capacity	18L
5	clean time	10~20min(0~99min adjustable)
6	rinse time	1~3min/times (0~10min adjustable)
7	hot air dry time	15~30min (0~60min adjustable)
8	rinse times	3~5times (1~9 times adjustable)
9	cleaning liquid temp	room temp~75°C
10	rinse DI water temp	room temp~75°C
11	hot air dry temp	room temp~99°C
12	liquid tank heater power	9KW

S/N	Item	Spec
13	temporary tank heater power	6KW
14	Hot air heater power	7.5KW
15	Resistivity range	0~18MΩ
16	electric pump	4.0KW
17	air pump	ARO 1 Inch
18	liquid Spray pressure	0~5kgf/cm2
19	liquid filter	1um
20	DI water filter	1um
21	Air vent size	φ100XH30(mm)
22	Power/air supply	AC380V,50/60HZ,65A /0.5~0.7Mpa,200~400L/Min
23	Machine size	L1300xW1200xH1850 (mm)
24	Machine weight	600KG

Comparison before and after wash -1

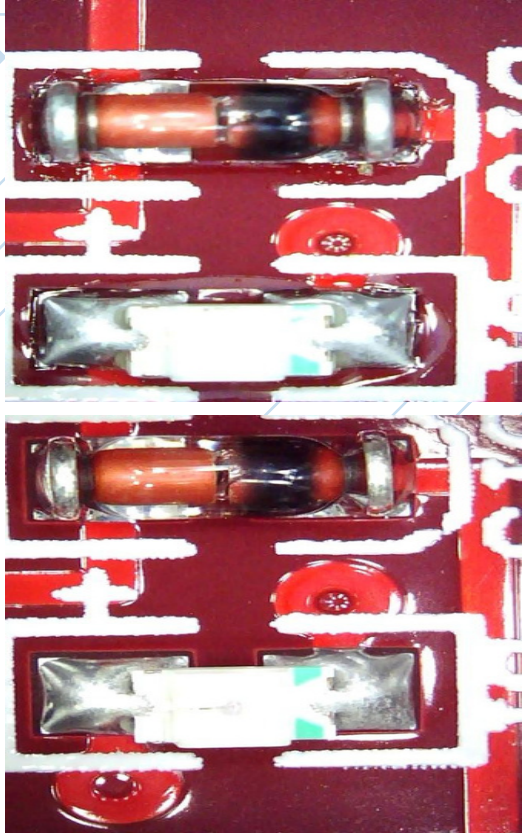

Comparison before and after wash -2

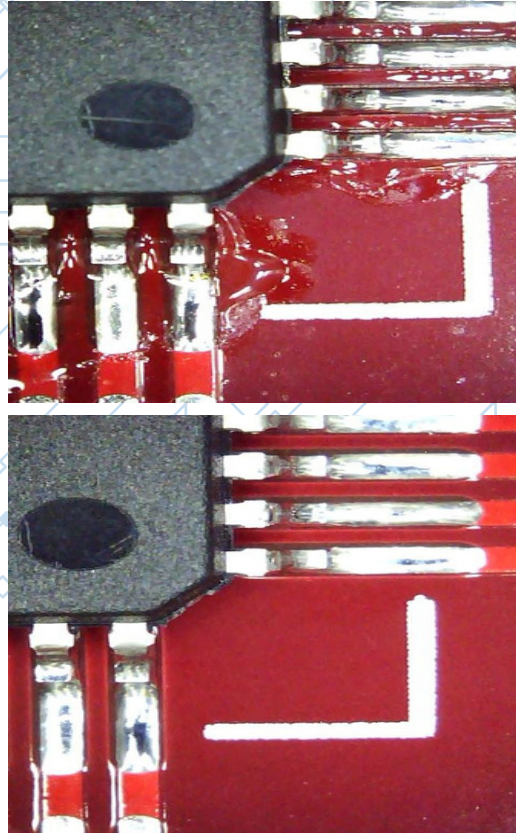

Comparison before and after wash -3

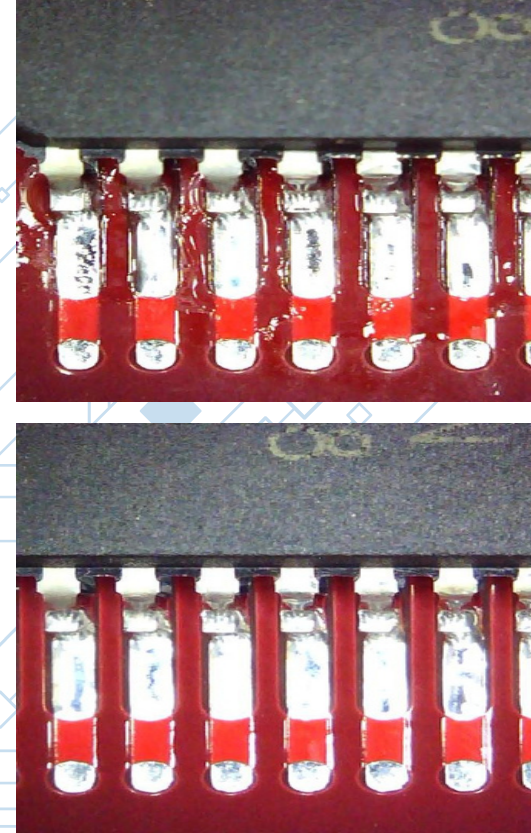

Comparison before clean-4

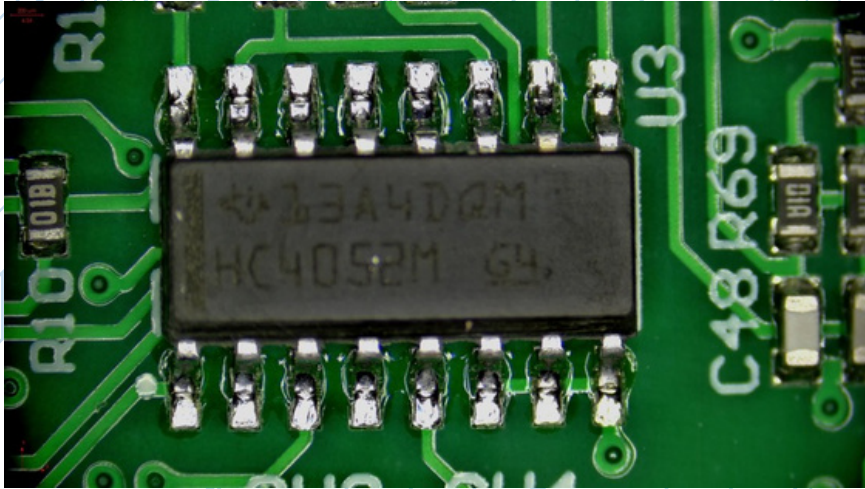

Comparison after clean-4

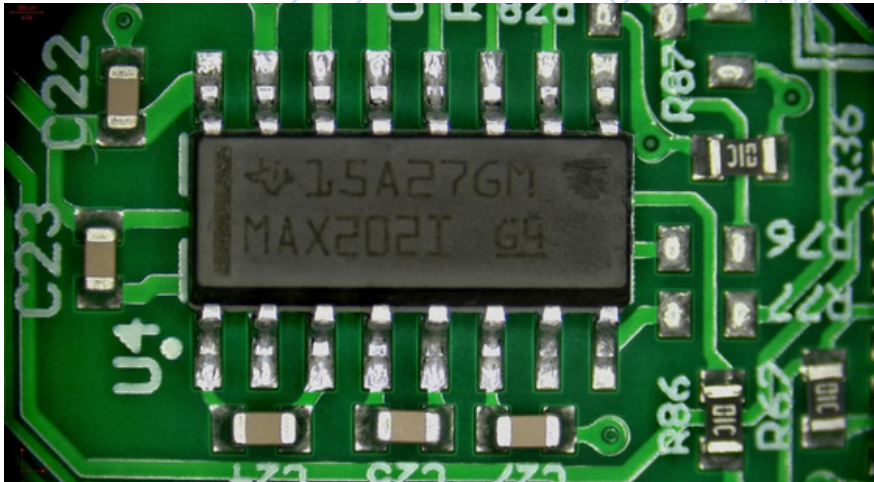

Comparison before clean-5

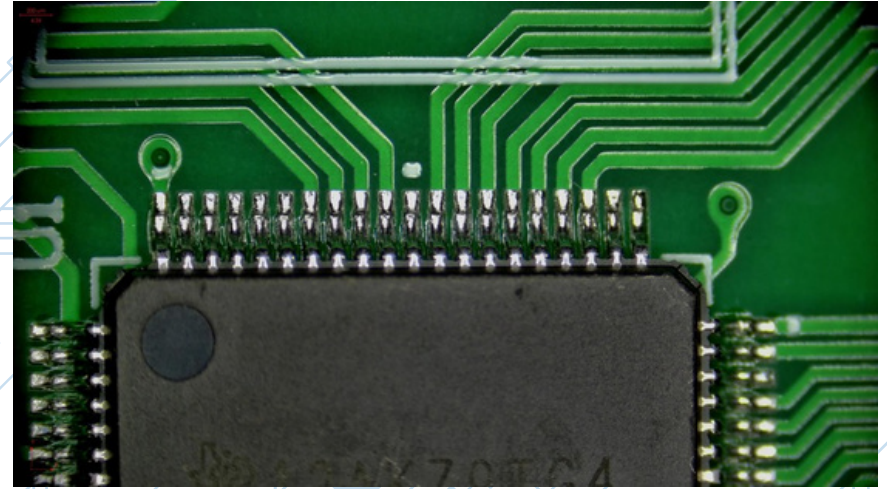

Comparison after clean-5

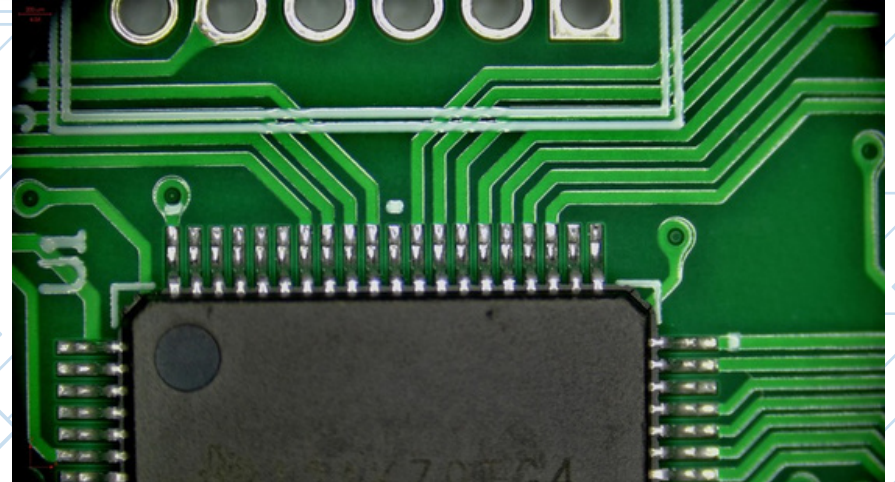

1. Application Range

This technical spec are only applicable for our DI water machine.

2. Name and Model: DI water machine; Model: DI-200.

3. Construction:

DI-250 is used to turn tap water into DI water and supply to our PCBA cleaning machine **YC-510**

for DI water rinse after liquid cleaning.

DI-250 are made up of previous treatment system, RO (RO Reverse Osmosis) system and MB(Mixed resin bed)system.

According to tape water quality, 60% of tape water will be turn into DI water and the rest 40% will be discharged to sewer.

DI-250 technical charactors

1. By adopting advanced DI water making process, the machine making DI water autotomatically, output water quality is stable.

2. By using famous spare parts, the system working stable, low electric consumption, DI water high output.

3. Good quality pipes, more stable.

4. By adding MB levels, not only the DI water output raised, but also DI water quality is improved.

5. enclosed and integrated design, compact and firm.



**DI water
machine**

4. DI-250 Technical SPEC:

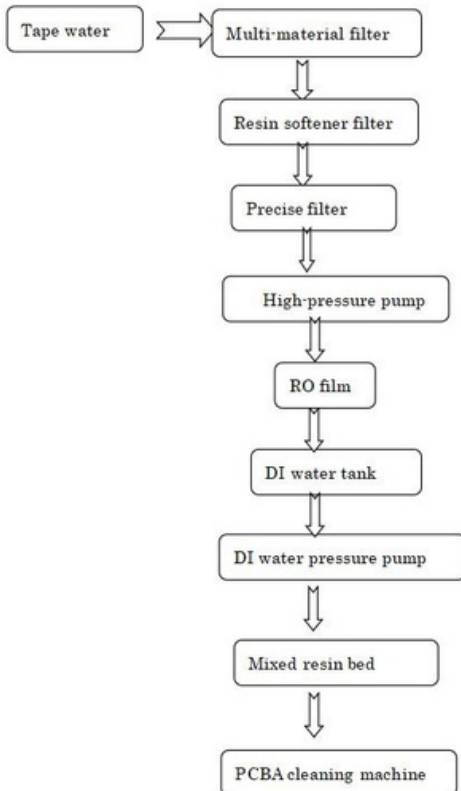

S/N	ITEM	SPEC	REMARKS
1	Tap water supply	1.5T/Hour	
2	Tape water supply pressure	0.15~0.3Mpa	
3	DI water output	250L/H	
4	DI water tank capacitor	160L	
5	DI water resistivity	≥10MΩ	
6	DI water pressure pump	0.37KW	Nanfang
7	Multi-material filter	25L Quartz Sand+ Carbon	
8	Cationic softener	25L cation resin	
9	Filter	20inch 1-5um PP filter cores	2cps
10	High pressure pump	1.1KW	Nanfang
11	RO film	DOW40*40	1pcs
12	MB ion		2 barrels
13	Power	AC380V,50/60HZ,1.6KW	
14	Machine size	L1100xW1100xH1600 (mm)	
15	Weight	About 400kg	
16	Material	DI water tank --SUS304;Out frame and cover--SUS201	



Model : E-1500

1. Equipment Features

- Dedicated high-pressure spray system for water-based cleaning of stencils, misprinted boards, PCB/PCBA, and more.
- Dual pump and dual pipeline with heating system, enabling cleaning, rinsing, and hot air drying.
- Process flow: Cleaning — Chemical Isolation — Rinsing — Drying.
- Advanced fully automatic touch screen operation software with program file storage, ensuring simplified operation.
- System counting function, automatically tracking the number of cleaned stencils and filter cycle counts.
- Liquid and pump pressure displayed via panel pressure gauge for real-time equipment status feedback.
- Stable cleaning pressure with a wider process window, resolving SMT stencil tension issues during high-pressure cleaning.
- All-stainless steel body for durability and resistance to acidic and alkaline cleaning solutions.
- High-pressure blower + hot air drying for faster and more thorough drying results.

2. Cleaning Process Flow Chart

Np.	Process	Function	Cycle Time	Cleaning Medium	Set Temperature	Filtration Precision
2	Manual Loading					
2	Spray Cleaning	Cleaning	2–5 min	Water-based Cleaning Agent	40–60°C	10 µm
3	Spray Rinsing	Rinsing	2–5 min	Pure Water/Tap Water	40–60°C	10 µm
4	Hot Air Knife Drying	Drying	3–5 min	Hot Air	60–80°C	—
5	Manual Unloading	—	—	—	—	—

3. Cleaning System

During cleaning stencil remains stationary while the spray bars reciprocate left and right. All cleaning nozzles deliver high-pressure spray, providing full-surface scanning cleaning of the workpiece. The used cleaning solution flows directly back to the cleaning tank for circulation, filtration, and heating.

- Cleaning Medium: Water-based cleaning solution
- Cleaning Tank Material: SUS304
- Nozzle Material: SUS304
- Pump Pressure: 0.2–0.4 MPa
- Pump Flow Rate: 4 T/H
- Pump Head: 45 m
- Filtration Precision: 10 µm

During rinsing, the stencil remains stationary while the spray bars reciprocate left and right. All rinsing nozzles deliver high-pressure DI water spray, providing full-surface scanning rinsing of the workpiece. The used DI water flows directly back to the rinsing tank for circulation, filtration, and heating.

- Rinsing Medium: DI water
- Rinsing Tank Material: SUS304
- Nozzle Material: SUS304
- Pump Pressure: 0.2–0.4 MPa
- Pump Flow Rate: 4 T/H
- Pump Head: 45 m
- Filtration Precision: 10 µm

4.Storage Tank

The storage tank is used for recovery, storage, and filtration of the liquid after spraying. Two stainless steel primary filter screens are installed at the tank outlet to protect the cleaning pump, followed by a 10 µm filter for further purification.

5.Water Circulation System

The cleaning chamber provides primary mesh filtration, the liquid tank provides secondary mesh filtration, and the stainless steel single-core filter provides tertiary filtration.

6.Liquid Level Sensor

Due to liquid evaporation and continuous consumption during repeated cleaning cycles, the sensor detects the upper, middle, and lower limits of liquid storage to trigger alarms and alert operators to replenish the liquid.

7.Temperature Control Device

The temperature inside the liquid tank is controlled by a temperature controller via thermocouple detection to maintain the set target temperature.

8.Heating Device

The electric heating tube system enhances cleaning efficiency by raising the temperature of the cleaning solution.

9.Drying Device

The high-pressure air knife system generates high-speed airflow from a high-pressure blower, which is heated via heating tubes and then directed through air knives across the cleaned workpiece surface to rapidly blow off water droplets, achieving fast and thorough drying.

Item	Specification
Machine Dimensions(mm)	L1870×W1220×H1900
Voltage	Three-phase 380V (three-phase five-wire)
Total Power (kW)	25
Rated Current (A)	25
Air Supply	0.4–0.6 MPa
Exhaust Port	125 mm
Cleaning Heating Power	7 kW
Cleaning Tank Capacity	45 L (High Level)
Rinsing Heating Power	7 kW
Rinsing Tank Capacity	45 L (High Level)
Cleaning Time	2–5 min
Rinsing Time	2–5 min
Drying Time	2–4 min
Filter Cartridge	10 μm, 10 inch
Max Cleaning Range	1500×800×40 mm
Cleaning Stencil Size	Below 1500×800×40 mm
Solder Paste Cleaning Time	8–12 min
Equipment Weight	600 kg
Cleaning Method	Spray Cleaning — Spray Rinsing — Air Knife Drying
Operation Control	PLC + Touch Screen (One-button Start)

Online fully automatic PCB depaneling machine solution (YD-700)

Contents

- Overall Appearance
- Technical Parameters & Operation Process
- Component Instructions
- Technical Specifications

1. Appearance Diagram

- Overall dimensions of the equipment: L2100*W1350*H1750mm



2. Overall structure introduction

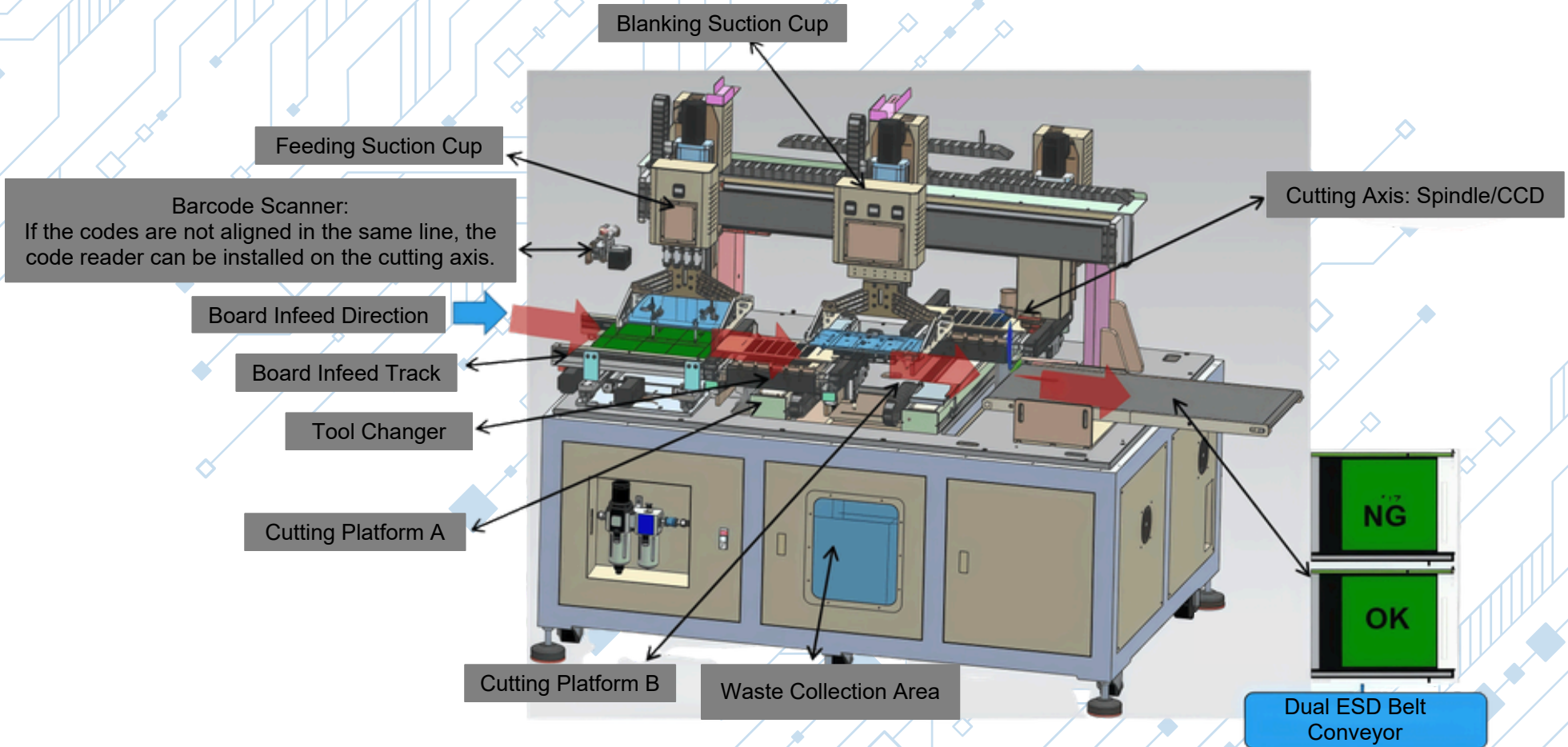

1.PCB Separator Technical Parameters

YD-700			
Main Power Supply	AC220V 50Hz/3KW	Weight	≈1200kg
Board Infeed Direction	Left→Right	Board Infeed Mode	Single-section Track
Track Width Adjustment	Automatic	Signal Communication	SMEMA
Cutting Size	max 300*300 mm min 50*50 mm	Cutting Speed	1-100 mm/s Adjustable
Coordinate Moving Speed	1000 mm/s	Operating System	WIN7/10
PCB Positioning	Fixture Positioning	Programming Mode	Online/Offline Programming/Visual Teaching
Cutting Precision	±0.1mm	Repeat Positioning Precision	±0.02mm
Milling Cutter	φ0.8 - 3mm Right-hand Rotation	Dust Collection Mode	Upper Suction/Lower Suction (Optional)
Spindle Speed	60000-100000 rpm/min	MES	Yes
Spindle Cooling	Compressed Air Cooling	Tool Detection	Broken Tool Detection
Automatic Tool Change	Yes	Operation Permission	Yes
Host Control	Industrial Computer	Operation Mode	Human-Machine Interface
Static Elimination	Ion Wind Bar	Filter Core Cleaning	With Filter Function
Safety Protection	Safety Door and Lock		

2.PCB Separator Operation Process Description

No.	Action Process	Function Description	Remarks
1	PCBA Enters Track	The track stop plate sensor detects the product, the conveyor belt decelerates and stops; the code scanning function is enabled.	
2	Suction Cup Material Taking	The suction cup mechanism descends, sucks up the board and places it into the left processing station.	
	PCBA Enters Track	The track stop plate sensor detects the product, the conveyor belt decelerates and stops; the code scanning function is enabled.	
3	Left Station Pressing Plate	The pressing plate cylinder presses down.	
	Suction Cup Material Taking	The suction cup mechanism descends, sucks up the board and places it into the right processing station.	
4	Cutting Left Station	The CCD takes photos to locate the Mark of the board at the left station and cuts after coordinate compensation.	
5	Left Station Discharging	<ul style="list-style-type: none"> a. After the left PCBA is cut, the cover plate is decompressed and moved to the rear; b. The cutting axis moves to the right station; c. The suction cup moves to the left station, sucks up the product and the board edge simultaneously and transports them to the discharging platform; d. The suction cup first places the product into the discharging fixture and then returns to the waste position to discard the board edge. 	
6	Right Station Pressing Plate	The pressing plate mechanism moves to the right processing station, and the pressing plate cylinder presses down.	
7	Cutting Right Station	The CCD takes photos to locate the Mark of the board at the right station and cuts after coordinate compensation.	
8	Right Station Discharging	<ul style="list-style-type: none"> a. After the right PCBA is cut, the cover plate is decompressed and moved to the rear; b. The cutting axis moves to the left station; c. The suction cup moves to the right station, sucks up the product and the board edge simultaneously and transports them to the discharging platform; d. The suction cup first places the product into the discharging fixture and then returns to the waste position to discard the board. 	

Broken Blade Inspection Instructions

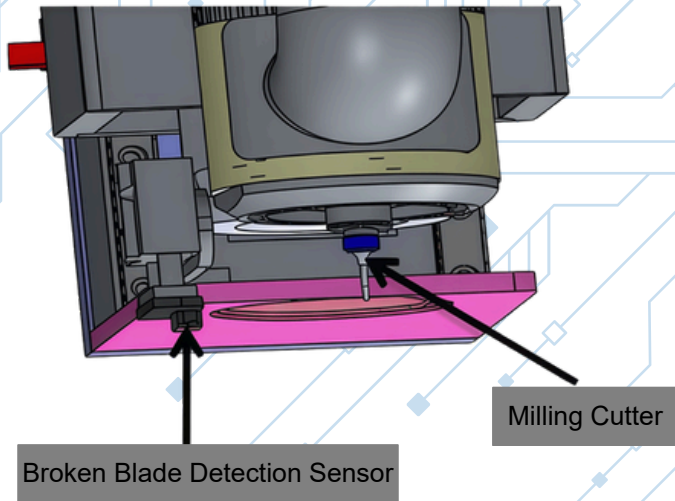

Instructions:

1. Blade breakage detection: Detected after each panel is cut.
2. The equipment will alarm and stop if the sensor detects a blade malfunction.

Error-Proofing Structure for NG Products

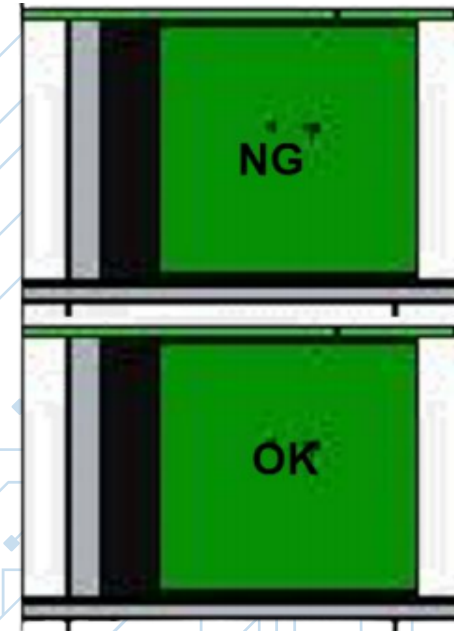

Instruction:

When an NG board appears, the board is placed directly into the NG board outlet when retrieving it, clearly distinguishing between NG and OK boards and preventing the possibility of the person retrieving the wrong board.

Automatic Tool Changer and Testing Instructions

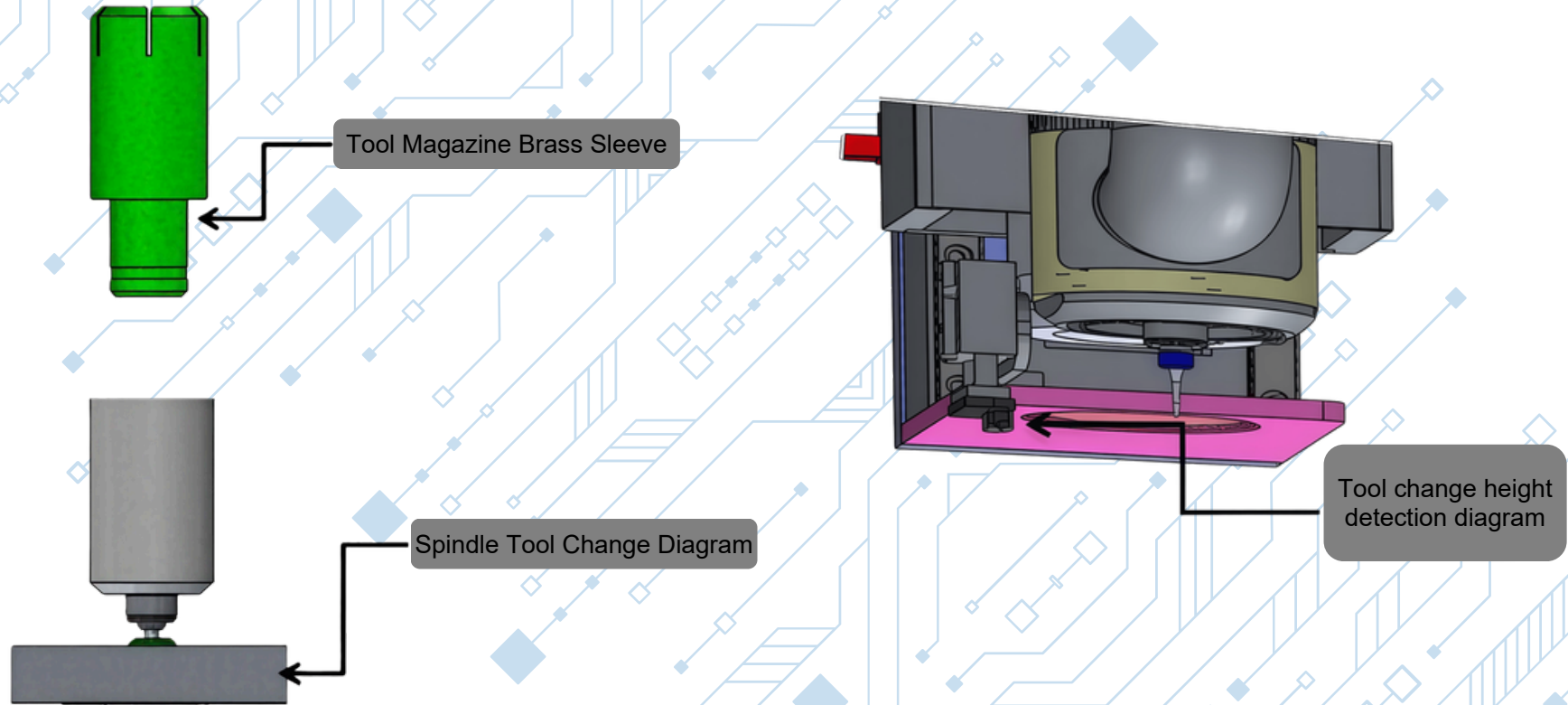

Offline Programming Instructions

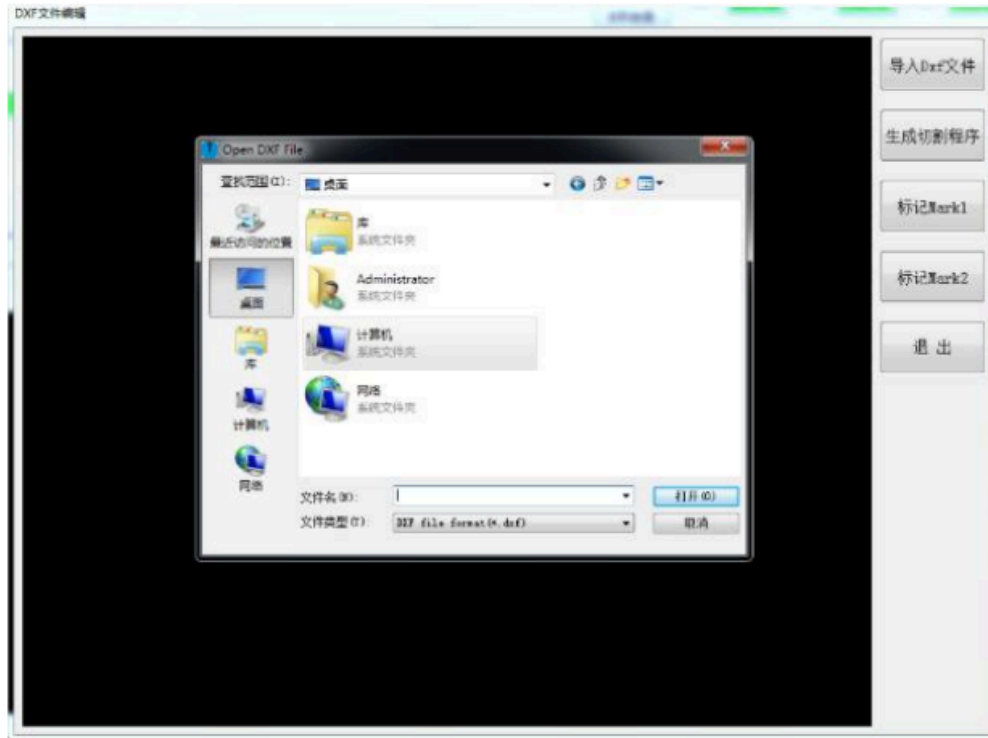

Instructions:

After drawing the path, markers, and other information from the product Gerber file using CAD, delete unnecessary layers and convert to DXF format;

PCB Depaneling Machine Error Prevention Requirements

No.	Position	Error-Proofing Description	Result
1	Safety Door Sensor	Uses a metal detection sensor (induction distance max: 10mm) to prevent false induction.	If the door is open (or not closed properly), the equipment alarms and cannot continue processing.
2	Air Source Pressure Monitoring	Equipped with a digital pressure gauge; when the pressure is lower than the set value, it outputs a signal.	If the pressure is lower than the set value, various cylinders of the equipment cannot act, and the software prompts an alarm.
3	Spindle Pressure Monitoring	Equipped with a digital pressure gauge; when the pressure is lower than the set value, it outputs a signal.	If the pressure is lower than the set value, the equipment spindle cannot start, and the software prompts an alarm.
4	Spindle Start and Tool Change Interlock	Prevents misoperation of the collet after the spindle starts, and vice versa.	Protects the spindle.
5	Vacuum Suction Cup	Equipped with a digital negative pressure gauge; when the vacuum value is lower than the set value, it outputs a signal.	If the pressure is lower than the set value, the equipment pauses processing, and the software prompts an alarm.
6	Vacuum On and Off Delay	The software can set the vacuum on and off time (unit: ms).	Ensures sufficient vacuum during picking and complete vacuum release during placing.
7	Axis Anti-Collision Buffer	Works when the limit sensor fails.	Installed at both ends of the lead screw to prevent mechanical collision damage to the lead screw, etc.
8	Static Elimination	Ion wind bar is installed on the cover plate shaft for real-time ESD protection during cutting.	Protects the product.

Cutting Visual Inspection

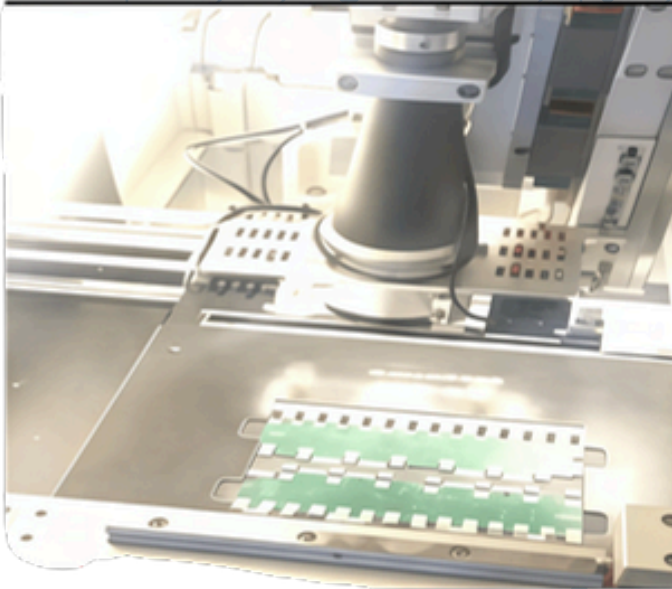

CCD Detection Upload

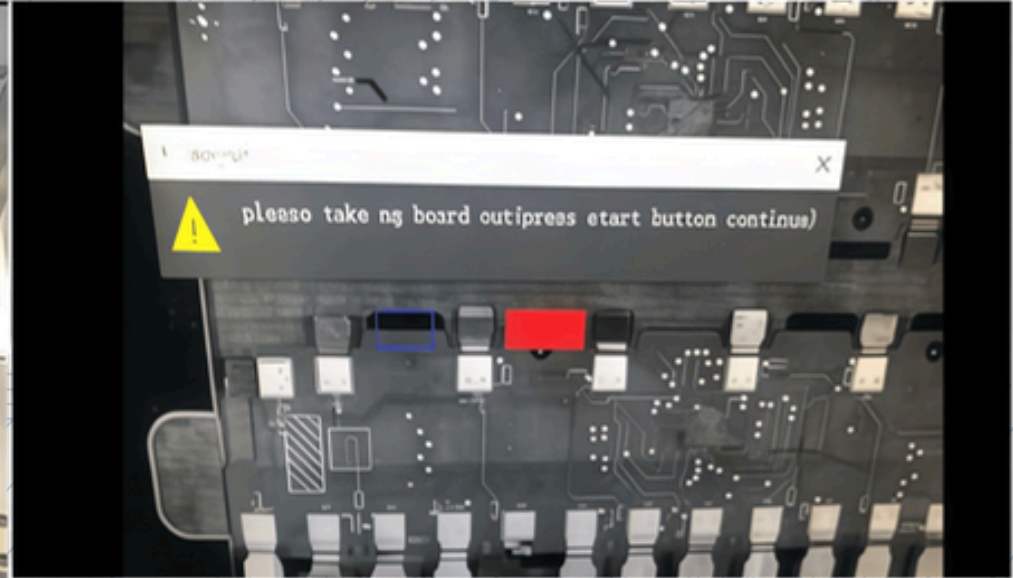

Software Analysis Entry Point

Vacuuming Instructions

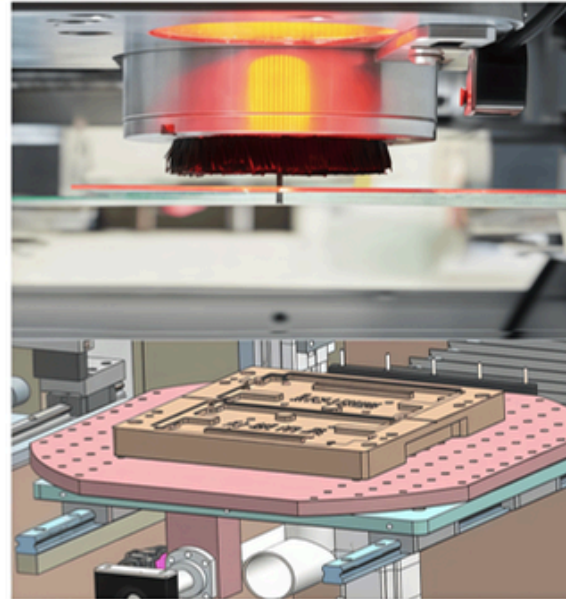

Instructions:

1. Uses a 5P high-powered vacuum cleaner.
2. Employs a top and bottom simultaneous vacuuming device to ensure the cleanliness of both sides of the PCBA.



Model	YDO-500
Power	AC 220V 50Hz
Temperature range	RT+10~250°C
Temperature fluctuation	±1.0°C
Temperature Resolution	0.1°C
Input power	800W
Volume	30L
Interior size	340*330*320mm
Dimensions	625*540*500mm
Shelf (std.)	2pcs
Timer	1~9999min



Model	YDO-530
Power	AC 220V 50Hz
Temperature range	RT+10~250°C
Temperature fluctuation	±1.0°C
Temperature Resolution	0.1°C
Input power	850W
Volume	50L
Interior size	420*350*350mm
Dimensions	705*610*530mm
Shelf (std.)	2pcs
Timer	1~9999min

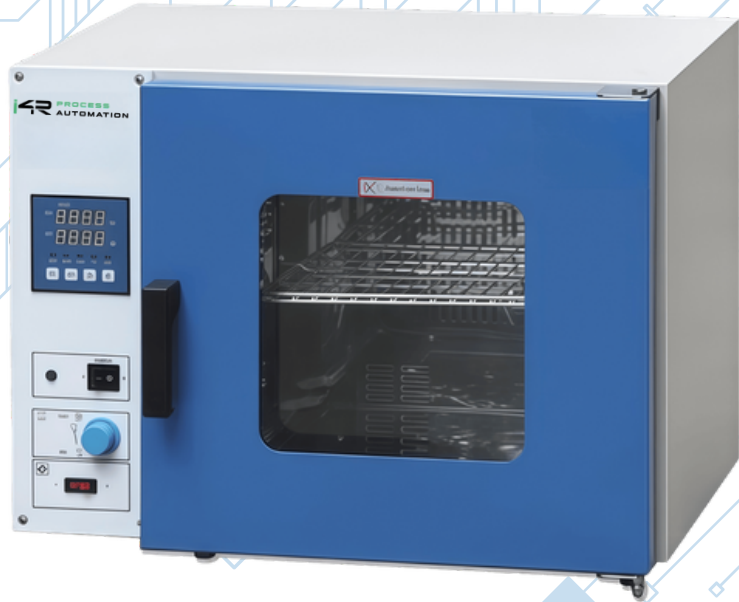

Model	YDO-630
Power	AC 220V 50Hz
Temperature range	RT+10~250°C
Temperature fluctuation	±1.0°C
Temperature Resolution	0.1°C
Input power	1100W
Volume	80L
Interior size	450*400*450mm
Dimensions	735*615*630mm
Shelf (std.)	2pcs
Timer	1~9999min



Model	YDO-730
Power	AC 220V 50Hz
Temperature range	RT+10~250°C
Temperature fluctuation	±1.0°C
Temperature Resolution	0.1°C
Input power	1550W
Volume	136L
Interior size	550*450*550mm
Dimensions	835*670*730mm
Shelf (std.)	2pcs
Timer	1~9999min



Model	YDO-830
Power	AC 220V 50Hz
Temperature range	RT+10~250°C
Temperature fluctuation	±1.0°C
Temperature Resolution	0.1°C
Input power	2050W
Volume	220L
Interior size	600*545*650mm
Dimensions	880*800*830mm
Shelf (std.)	2pcs
Timer	1~9999min



Model	YDO-930
Power	AC 220V 50Hz
Temperature range	RT+10~250°C
Temperature fluctuation	±1.0°C
Temperature Resolution	0.1°C
Input power	2050W
Volume	260L
Interior size	600*545*750mm
Dimensions	880*800*930mm
Shelf (std.)	2pcs
Timer	1~9999min

CONTACT

 VENTAS@SOLUCINDE.COM

IF YOU WOULD LIKE A QUOTE, PLEASE
CONTACT US BY SCANNING OUR
WHATSAPP QR CODE



LOCATION MÉXICO
Zacatecas 503A, Lampacitos,
Huastecas de Lampacitos, 88780

WANT TO LEARN MORE ABOUT OUR
SOLUTIONS? VISIT OUR WEBSITE.

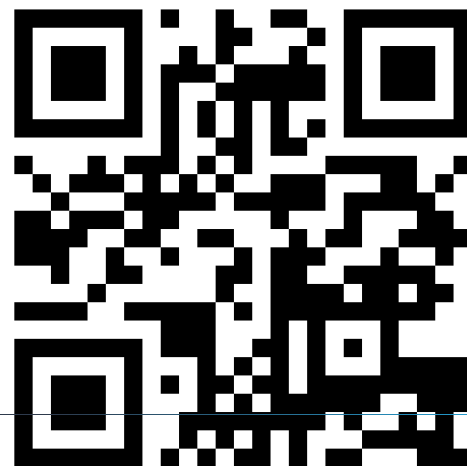

LOCATION USA
1124 N International
blvd suite 650, Hidalgo
Texas 78557

